

OPEN-TOP BOX ROLLER WITH 48" CROSSBAR AND TWO HBFB TRAY CLAMPS (HB9AX48) MATERIAL #65104001

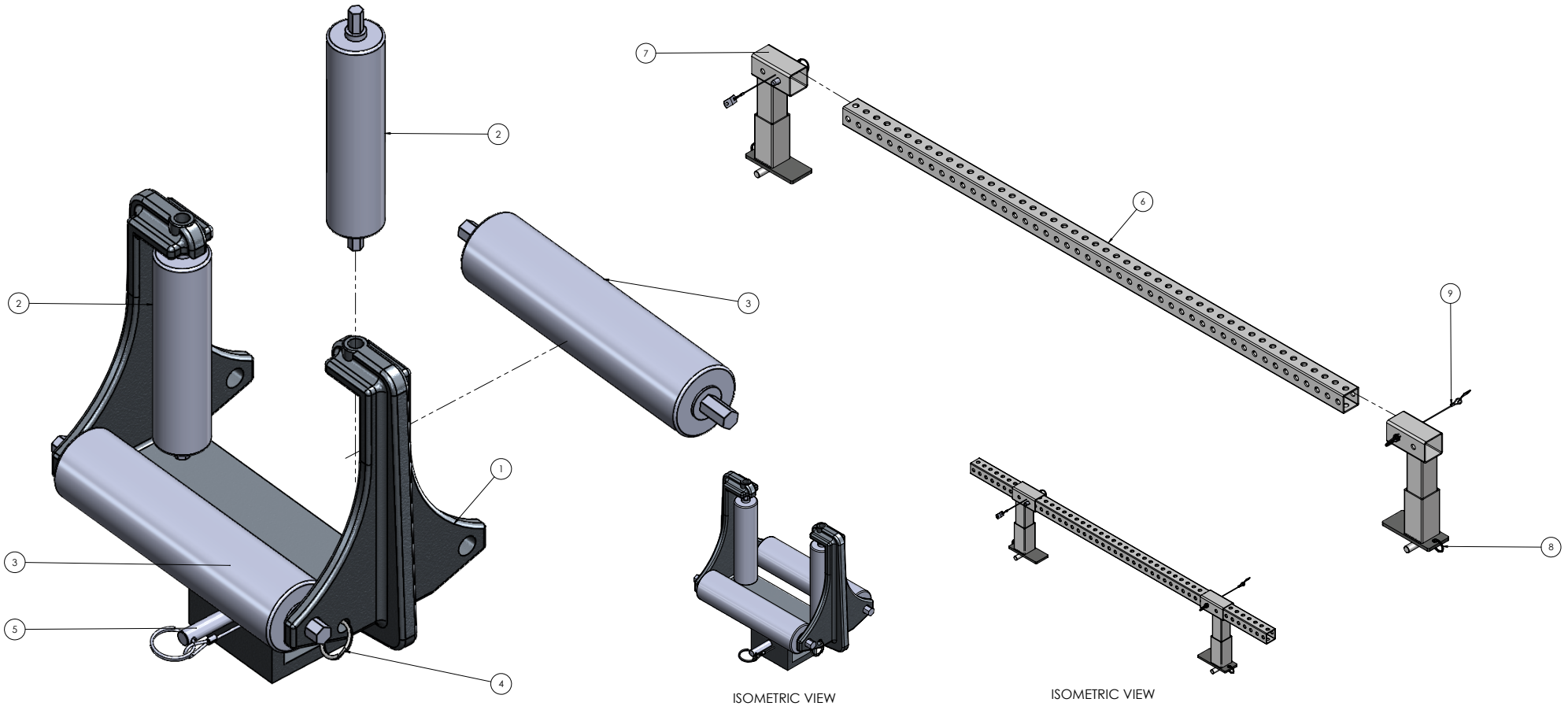

Item	Stock Number	Model	Description
1	73634040	HB9A-F	CASTING, FOR HB9A OPEN-TOP BOX ROLLER
2	67037440	EFG06	ROLLER, 1.38" DIAMETER, 6 BETWEEN FRAMES, 5/16 HEX
3	73633740	KG08	ROLLER, 1.9" DIAMETER USED ON HB 1A-9 & HB9A
4	90990A250*	MCMaster-CARR	18-8 STAINLESS STEEL SPLIT RING 31/32" OD, 51/64" ID, 1/8" THICK
5	94975A591*	MCMaster-CARR	18-8 STAINLESS STEEL RING-GRIP QUICK-RELEASE PIN WITH LANYARD, 3/8" DIAMETER, 2-5/8" USABLE LENGTH
6	73633940	HB-20-0270	CROSSBAR, 48" LONG, HB-20-0270
7	65095501	HBFB	TRAY CLAMP
8	90990A250*	MCMaster-CARR	18-8 STAINLESS STEEL SPLIT RING 31/32" OD, 51/64" ID, 1/8" THICK
9	94975A564*	MCMaster-CARR	18-8 STAINLESS STEEL RING-GRIP QUICK-RELEASE PIN WITH LANYARD, 3/8" DIAMETER, 1-13/16" USABLE LENGTH

*Indicates a McMaster-Carr Part that can be purchased at www.mcmaster.com



1-855-798-6657 | SOUTHWIRE.COM

©2025 Southwire Company, LLC. All rights reserved.
 ®Registered Trademark & ™Trademark of Southwire Company, LLC.