



Southwire™

RIGID CONDUIT BODIES

THREADED X TYPE - MALLEABLE IRON

FEATURES

- NPT tapered hubs

APPLICATION

- Provides access to conductors for pulling, splicing and maintenance

STANDARD MATERIAL

- Malleable iron

STANDARD FINISH

- Zinc plated, aluminum enameled

CERTIFICATIONS

- UL 514A
- Fed. Spec. W-C-586D, A-A-50563
- NEMA FB 1



X1M

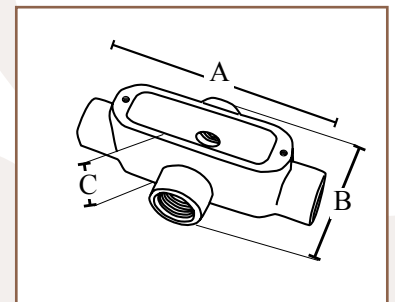

PART #	SIZE	WIRE SIZE		INTERNAL VOLUME (IN ³)	MASTER QTY.	WEIGHT/CASE (LBS.)	A	B	C
		MAX. NUMBER	MAX. SIZE						
X1M	1/2"	---	---	5.6	10	12	5.25"	2.8125"	1.75"
X2M	3/4"	3	6 AWG	9.5	10	14	6.0625"	2.9375"	2"
X3M	1"	3	4 AWG	15	5	23	7.125"	3.5625"	2.25"
X4M	1-1/4"	3	2 AWG	33	5	20	9.125"	4.4375"	2.5625"
X5M	1-1/2"	3	1 AWG	36	2	22	9.125"	4.4375"	2.75"
X6M	2"	3	2/0 AWG	75	1	16	11.75"	5.375"	3.4375"

Rev. 0, 03/23

**BUILT FOR DURABILITY.
BUILT FOR RELIABILITY.
BUILT FOR WORK.™**

1-855-798-6657 | SOUTHWIRE.COM

©2023 Southwire Company, LLC. All rights reserved.
*Registered Trademark & ™Trademark of Southwire Company, LLC.