



Southwire™

BLANK COVER

DOUBLE

FEATURES

- Companion to Topaz double PVC boxes
- Rust proof; corrosion resistant

APPLICATIONS

- For use with a double gang FS type box

STANDARD MATERIAL

- PVC



1314

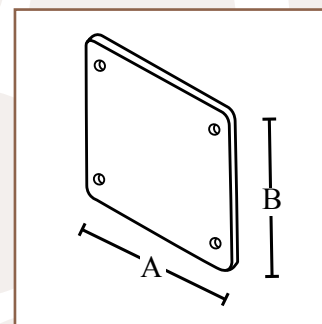

PART #	MASTER QTY.	WEIGHT/CASE (LBS.)	A	B
1314	25	5	4.5625"	4.5625"

Rev. 0, 06/23

**BUILT FOR DURABILITY.
BUILT FOR RELIABILITY.
BUILT FOR WORK.™**

1-855-798-6657 | SOUTHWIRE.COM

©2023 Southwire Company, LLC. All rights reserved.
*Registered Trademark & ™Trademark of Southwire Company, LLC.