

8 7 6 5 4 3 2 1

REVISIONS				
ZONE	REV.	DESCRIPTION	DATE	APPROVED
-	-	INITIAL RELEASE	-	-



ITEM NO.	PART NUMBER	DESCRIPTION	QTY.
1	780233	RLR HD. WLDMT W/ADJ SCREW	1
2	780507	RUBBER WHEEL W/BUSHINGS AD-9R	2
3	771101	SCREW, HHC 3/8 - 16 X 2-3/4	2
4	772355	NUT, INSERT LOCK 3/8-16	3

<p>PROPRIETARY AND CONFIDENTIAL THE INFORMATION CONTAINED IN THIS DRAWING IS THE SOLE PROPERTY OF SUMNER MFG LLC. ANY REPRODUCTION IN PART OR AS A WHOLE WITHOUT THE WRITTEN PERMISSION OF SUMNER MFG LLC IS PROHIBITED.</p>	<p>UNLESS OTHERWISE SPECIFIED DIMENSIONS ARE IN INCHES.</p> <p>FABRICATION TOLERANCES: FRACTIONAL/WHOLE: ±1/32 ANGULAR: BEND ±1/2°</p> <p>MACHINE SHOP TOLERANCES: TWO PLACE DECIMAL: ±.03 THREE PLACE DECIMAL: ±.010</p> <p>INTERPRET GEOMETRIC TOLERANCING PER: THIRD ANGLE GD&T</p>	<p>NOTES/COMMENTS: 1. BREAK ALL EDGES</p>	<table border="1"> <tr> <td></td> <td>NAME</td> <td>DATE</td> </tr> <tr> <td>DRAWN</td> <td></td> <td></td> </tr> <tr> <td>CHECKED</td> <td>DNU</td> <td>DNU</td> </tr> <tr> <td>ENG APPR.</td> <td>DNU</td> <td>DNU</td> </tr> <tr> <td>MFG APPR.</td> <td>DNU</td> <td>DNU</td> </tr> <tr> <td>Q.A.</td> <td>DNU</td> <td>DNU</td> </tr> </table>		NAME	DATE	DRAWN			CHECKED	DNU	DNU	ENG APPR.	DNU	DNU	MFG APPR.	DNU	DNU	Q.A.	DNU	DNU	<p>SUMNER MFG LLC</p>
		NAME	DATE																			
	DRAWN																					
	CHECKED	DNU	DNU																			
	ENG APPR.	DNU	DNU																			
MFG APPR.	DNU	DNU																				
Q.A.	DNU	DNU																				
				<p>TITLE:</p>																		
				<p>DWG. NO. 780499</p>																		
				<p>REV</p>																		
				<p>SCALE: SHEET 1 OF 1</p>																		

8 7 6 5 4 3 2 1

8 7 6 5 4 3 2 1

REVISIONS				
ZONE	REV.	DESCRIPTION	DATE	APPROVED
-	-	INITIAL RELEASE	-	-

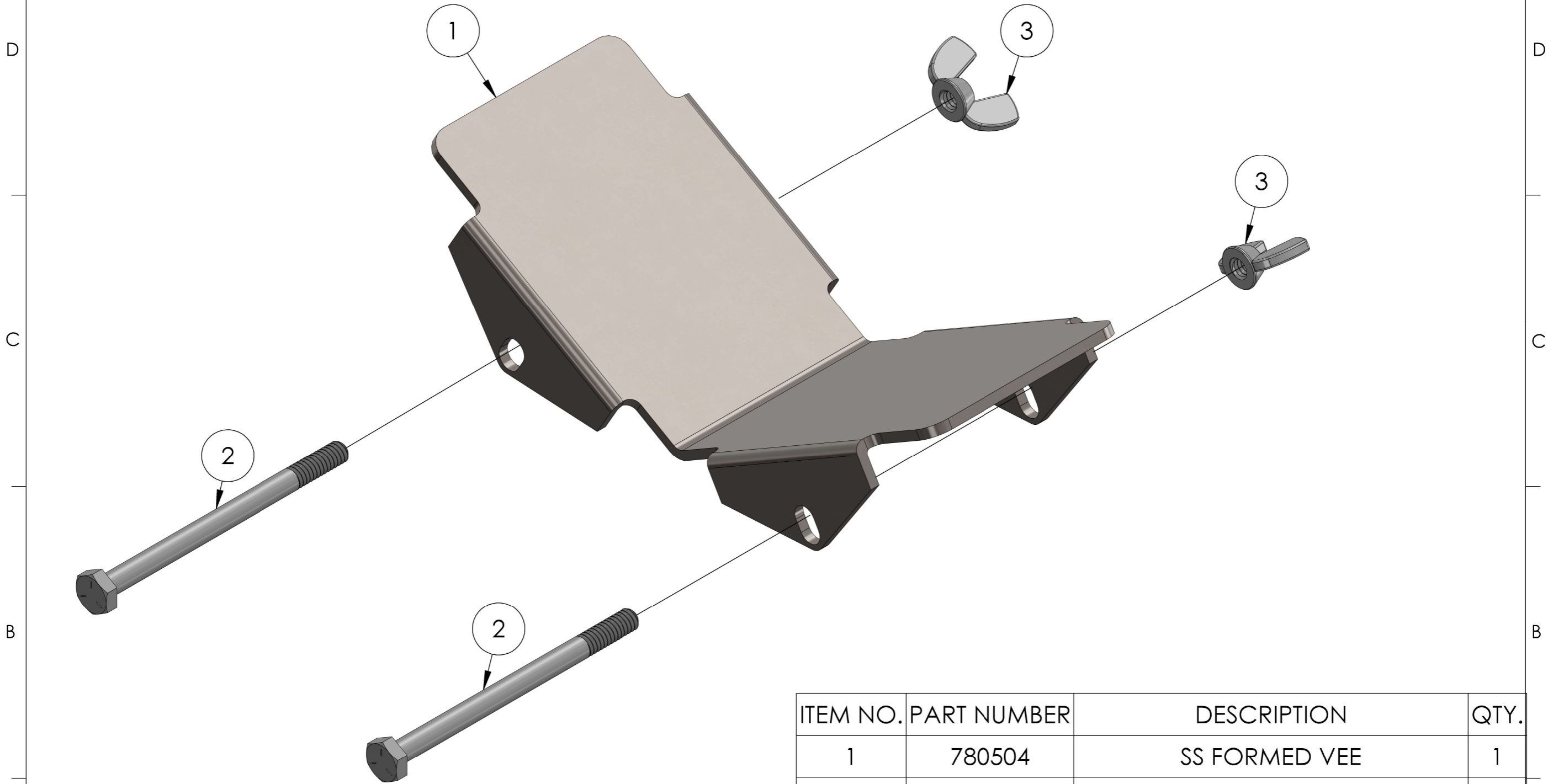

ITEM NO.	PART NUMBER	DESCRIPTION	QTY.
1	780504	SS FORMED VEE	1
2	771028	SCREW, HHC 1/4-20 X 3-1/2	2
3	775023	NUT, WING 1/4-20 COLD FORGED	2

PROPRIETARY AND CONFIDENTIAL THE INFORMATION CONTAINED IN THIS DRAWING IS THE SOLE PROPERTY OF SUMNER MFG LLC. ANY REPRODUCTION IN PART OR AS A WHOLE WITHOUT THE WRITTEN PERMISSION OF SUMNER MFG LLC IS PROHIBITED.	UNLESS OTHERWISE SPECIFIED DIMENSIONS ARE IN INCHES. FABRICATION TOLERANCES: FRACTIONAL/WHOLE: ±1/32 ANGULAR: BEND ±1/2° MACHINE SHOP TOLERANCES: TWO PLACE DECIMAL: ±.03 THREE PLACE DECIMAL: ±.010	NOTES/COMMENTS: 1. BREAK ALL EDGES	NAME DATE SUMNER MFG LLC	
	INTERPRET GEOMETRIC TOLERANCING PER: THIRD ANGLE GD&T	MATERIAL AS NOTED	DRAWN CHECKED DNU DNU ENG APPR. DNU DNU MFG APPR. DNU DNU DNU Q.A. DNU DNU DNU	TITLE:
	FINISH DNU	MATERIAL CODE 7XXXX	NEXT ASSEMBLY 7XXXX	DWG. NO. 780502
	WEIGHT 1.127 LBS.	PARTS PER UNIT X	SCALE:	REV SHEET 1 OF 1

8 7 6 5 4 3 2 1



REVISION HISTORY				
REV	REVISED	DESCRIPTION	APPROVED	DATE
DV1	DRAWN BY	INITIAL RELEASE	APRV BY	6/17/2016

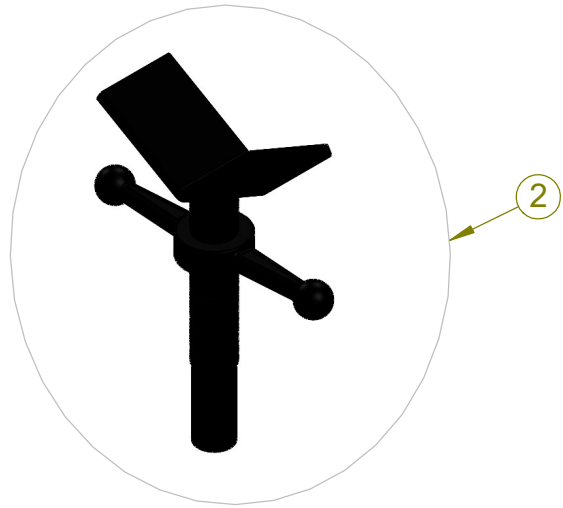

ITEM NO.	PART NUMBER	DESCRIPTION	QTY.
1	781336	BASE HI FOLD-A-JACK	1
2	780518	VEE HD ASSY., B-16F	1

UNLESS OTHERWISE SPECIFIED DIMENSIONS ARE IN INCHES ANGLES $\pm 1^\circ$ X.X $\pm .1$ X.XX $\pm .01$ X.XXX $\pm .005$	AUTHENTICATION NAME _____ DATE _____ DRAWN PER _____ 6/6/2023 PROJECT APRV BY _____ 6/25/2015 ENGINEER _____		
	TITLE: HI FOLD-A-JACK W/VEE HEAD		
CRITICAL DIMENSION .XXX \pm .XX DENOTES REQUIRED INSPECTION DIMENSION.	THIS DOCUMENT IS ISSUED BY SOUTHWIRE ON THE UNDERSTANDING THAT IT IS STRICTLY CONFIDENTIAL AND MAY NOT BE REPRODUCED OR UTILIZED IN ANY WAY WITHOUT THE PRIOR WRITTEN PERMISSION OF SOUTHWIRE. PRINTED COPIES OF THIS DOCUMENT ARE REFERENCE ONLY. MASTER VERSION IS MAINTAINED ONLINE IN OMNIFY.		SIZE DWG. NO. B 781300
ISO STANDARD FOR 3rd ANGLE PROJECTION 	DO NOT SCALE DRAWING USE DIMENSIONS ONLY		SCALE: 1:12 WEIGHT: _____ SHEET 1 OF 1
TEMPLATE NUMBER: 631-00023			



REVISION HISTORY				
REV	REVISED	DESCRIPTION	APPROVED	DATE
DV1	DRAWN BY	INITIAL RELEASE	APRV BY	6/17/2016

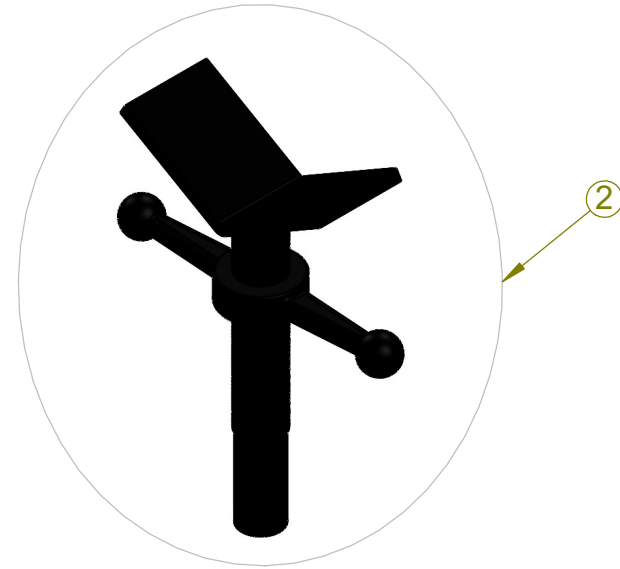

ITEM NO.	PART NUMBER	DESCRIPTION	QTY.
1	781355	BASE LOW FOLD-A-JACK	1
2	780518	VEE HD ASSY., B-16F	1

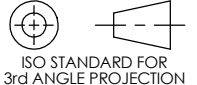
UNLESS OTHERWISE SPECIFIED DIMENSIONS ARE IN INCHES ANGLES ±1° X.X ±.1 X.XX ±.01 X.XXX ±.005	AUTHENTICATION		 TITLE: LOW FOLD-A-JACK W/VEE HEAD
	NAME	DATE	
CRITICAL DIMENSION .XXX±.XX DENOTES REQUIRED INSPECTION DIMENSION.	DRAWN PER	6/6/2023	SIZE DWG. NO. B 781310
	PROJECT ENGINEER	APRV BY	
 ISO STANDARD FOR 3rd ANGLE PROJECTION	THIS DOCUMENT IS ISSUED BY SOUTHWIRE ON THE UNDERSTANDING THAT IT IS STRICTLY CONFIDENTIAL AND MAY NOT BE REPRODUCED OR UTILIZED IN ANY WAY WITHOUT THE PRIOR WRITTEN PERMISSION OF SOUTHWIRE. PRINTED COPIES OF THIS DOCUMENT ARE REFERENCE ONLY. MASTER VERSION IS MAINTAINED ONLINE IN OMNIFY.		SCALE: 1:8 WEIGHT: SHEET 1 OF 1
DO NOT SCALE DRAWING USE DIMENSIONS ONLY	TEMPLATE NUMBER: 631-00023		

8 7 6 5 4 3 2 1

REVISIONS				
ZONE	REV.	DESCRIPTION	DATE	APPROVED
-	-	INITIAL RELEASE	-	-

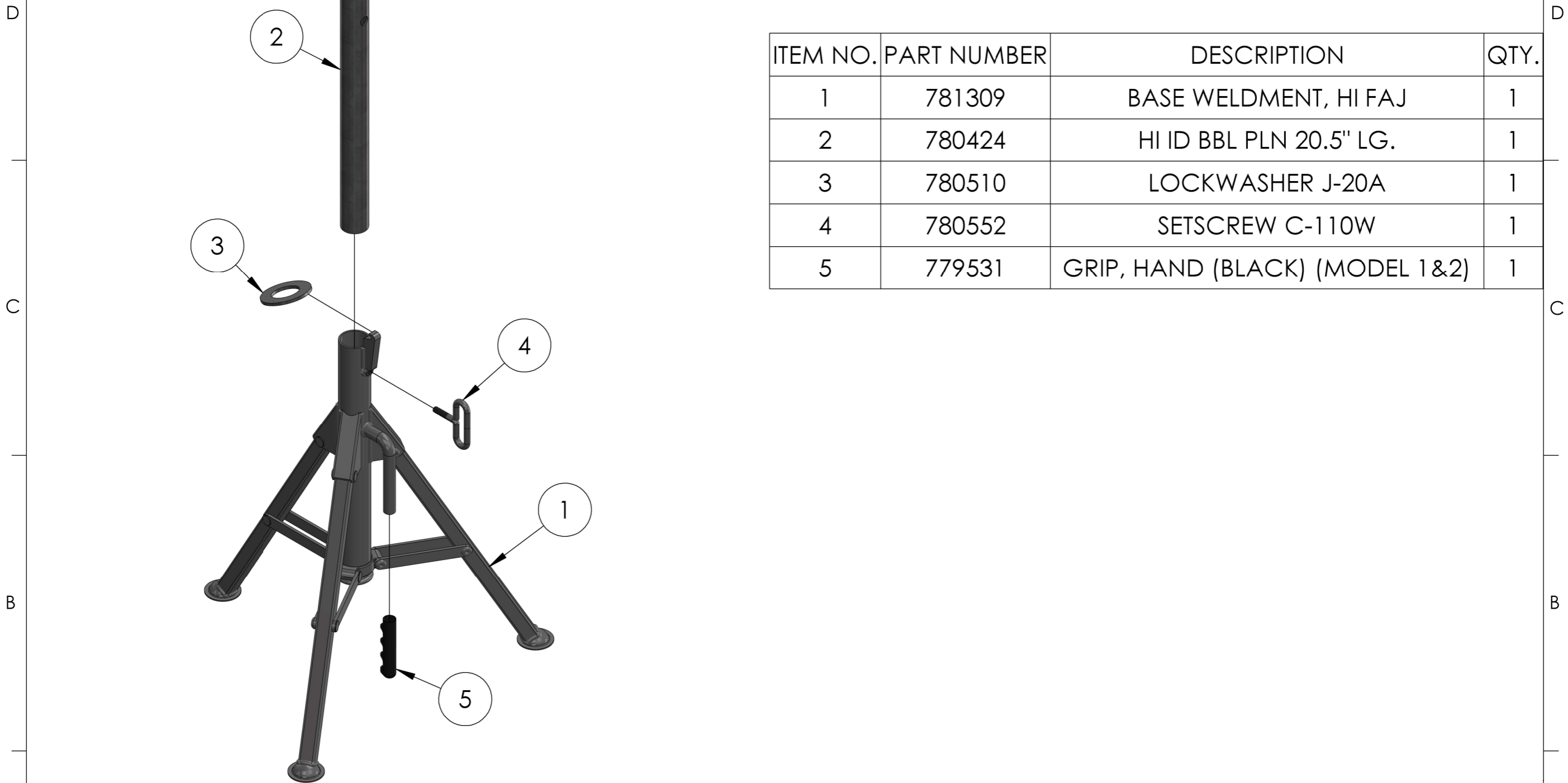

ITEM NO.	PART NUMBER	DESCRIPTION	QTY.
1	781309	BASE WELDMENT, HI FAJ	1
2	780424	HI ID BBL PLN 20.5" LG.	1
3	780510	LOCKWASHER J-20A	1
4	780552	SETSCREW C-110W	1
5	779531	GRIP, HAND (BLACK) (MODEL 1&2)	1

PROPRIETARY AND CONFIDENTIAL THE INFORMATION CONTAINED IN THIS DRAWING IS THE SOLE PROPERTY OF SUMNER MFG LLC. ANY REPRODUCTION IN PART OR AS A WHOLE WITHOUT THE WRITTEN PERMISSION OF SUMNER MFG LLC IS PROHIBITED.	UNLESS OTHERWISE SPECIFIED DIMENSIONS ARE IN INCHES. FABRICATION TOLERANCES: FRACTIONAL/WHOLE: ±1/32 ANGULAR: BEND ±1/2° MACHINE SHOP TOLERANCES: TWO PLACE DECIMAL: ±.03 THREE PLACE DECIMAL: ±.010 INTERPRET GEOMETRIC TOLERANCING PER: THIRD ANGLE GD&T	NOTES/COMMENTS: 1. BREAK ALL EDGES	NAME DATE	SUMNER MFG LLC	
	MATERIAL AS NOTED	FINISH DNU	DRAWN CHECKED DNU DNU ENG APPR. DNU DNU MFG APPR. DNU DNU DNU Q.A. DNU DNU DNU	TITLE:	
	WEIGHT 16.859 LBS.	PARTS PER UNIT X	MATERIAL CODE 7XXXX NEXT ASSEMBLY 7XXXX	DWG. NO. 781336 REV	
				SCALE: SHEET 1 OF 1	

8 7 6 5 4 3 2 1

8 7 6 5 4 3 2 1

REVISIONS				
ZONE	REV.	DESCRIPTION	DATE	APPROVED
-	-	INITIAL RELEASE	-	-

ITEM NO.	PART NUMBER	DESCRIPTION	QTY.
1	781360	BASE WELDMENT, LO FAJ	1
2	780422	LO ID BBL PLN 14.5" LG.	1
3	780510	LOCKWASHER J-20A	1
4	780552	SETSCREW C-110W	1

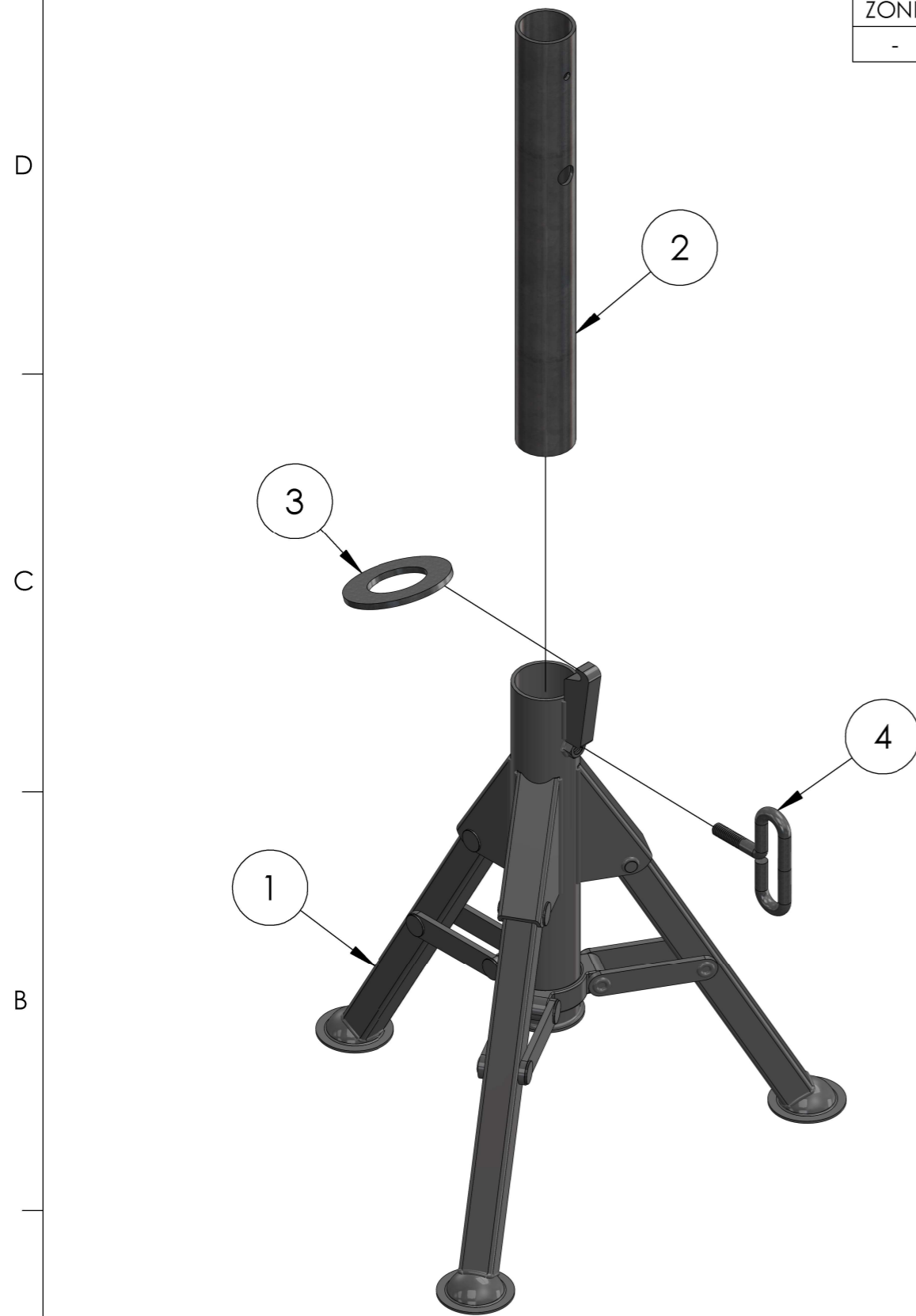

PROPRIETARY AND CONFIDENTIAL
 THE INFORMATION CONTAINED IN THIS DRAWING IS THE SOLE PROPERTY OF SUMNER MFG LLC. ANY REPRODUCTION IN PART OR AS A WHOLE WITHOUT THE WRITTEN PERMISSION OF SUMNER MFG LLC IS PROHIBITED.

UNLESS OTHERWISE SPECIFIED DIMENSIONS ARE IN INCHES.
FABRICATION TOLERANCES:
 FRACTIONAL/WHOLE: ±1/32
 ANGULAR: BEND ±1/2°
MACHINE SHOP TOLERANCES:
 TWO PLACE DECIMAL: ±.03
 THREE PLACE DECIMAL: ±.010
 INTERPRET GEOMETRIC TOLERANCING PER: THIRD ANGLE GD&T

NOTES/COMMENTS:
 1. BREAK ALL EDGES
 MATERIAL AS NOTED
 FINISH DNU
 WEIGHT 11.432 **LBS.**

	NAME	DATE
DRAWN		
CHECKED	DNU	DNU
ENG APPR.	DNU	DNU
MFG APPR.	DNU	DNU
Q.A.	DNU	DNU

SUMNER MFG LLC
 TITLE:
 DWG. NO. 781355
 SCALE: SHEET 1 OF 1
 REV

8 7 6 5 4 3 2 1

8 7 6 5 4 3 2 1

REVISIONS				
ZONE	REV.	DESCRIPTION	DATE	APPROVED
-	-	INITIAL RELEASE	-	-

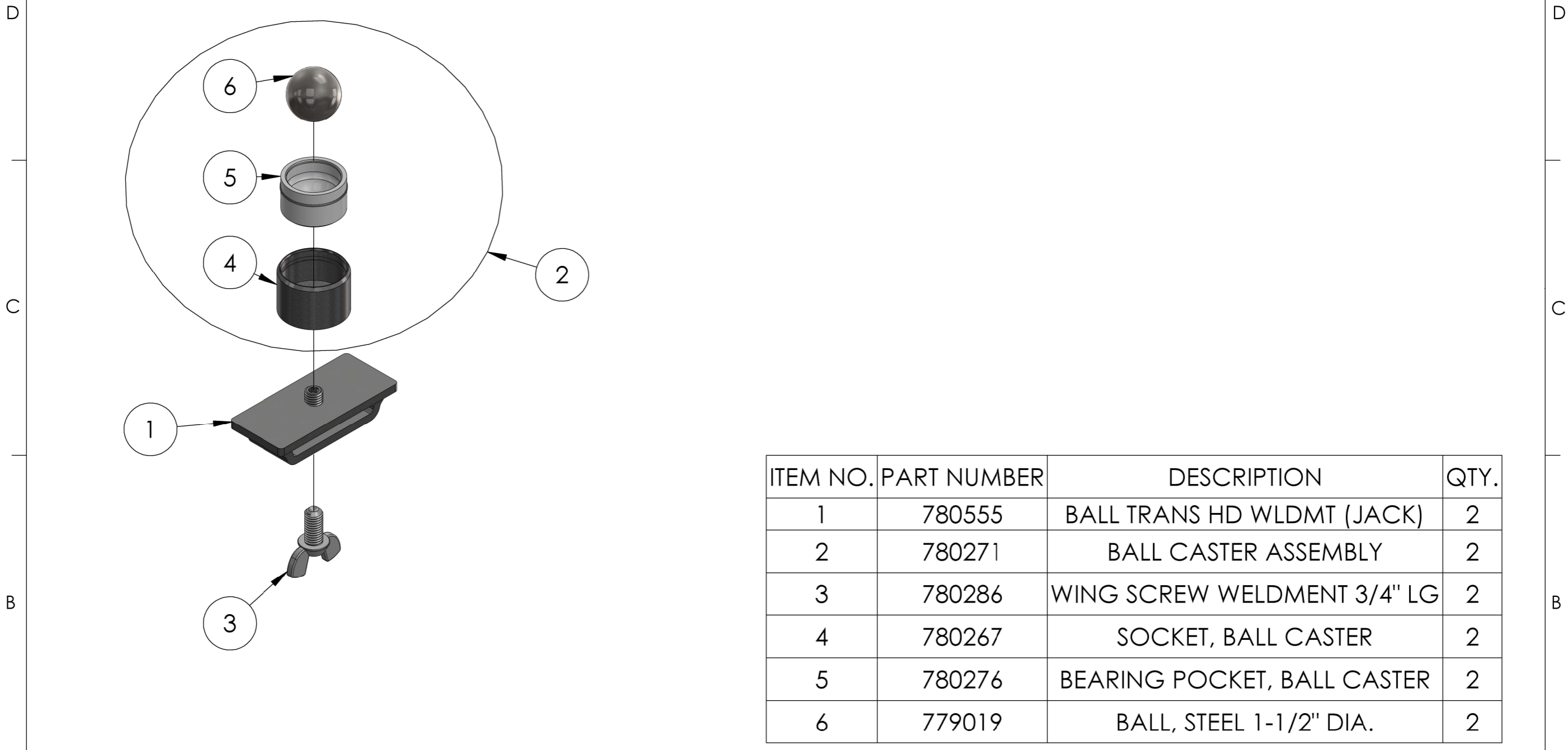

ITEM NO.	PART NUMBER	DESCRIPTION	QTY.
1	780555	BALL TRANS HD WLDMT (JACK)	2
2	780271	BALL CASTER ASSEMBLY	2
3	780286	WING SCREW WELDMENT 3/4" LG	2
4	780267	SOCKET, BALL CASTER	2
5	780276	BEARING POCKET, BALL CASTER	2
6	779019	BALL, STEEL 1-1/2" DIA.	2

PROPRIETARY AND CONFIDENTIAL THE INFORMATION CONTAINED IN THIS DRAWING IS THE SOLE PROPERTY OF SUMNER MFG LLC. ANY REPRODUCTION IN PART OR AS A WHOLE WITHOUT THE WRITTEN PERMISSION OF SUMNER MFG LLC IS PROHIBITED.	UNLESS OTHERWISE SPECIFIED DIMENSIONS ARE IN INCHES. FABRICATION TOLERANCES: FRACTIONAL/WHOLE: ±1/32 ANGULAR: BEND ±1/2° MACHINE SHOP TOLERANCES: TWO PLACE DECIMAL: ±.03 THREE PLACE DECIMAL: ±.010	NOTES/COMMENTS: 1. BREAK ALL EDGES	NAME DATE	SUMNER MFG LLC	
	MATERIAL AS NOTED	FINISH DNU	DRAWN CHECKED DNU DNU ENG APPR. DNU DNU MFG APPR. DNU DNU DNU Q.A. DNU DNU DNU	TITLE:	
	WEIGHT 2.448 LBS.	FINISH DNU	MATERIAL CODE 7XXXX NEXT ASSEMBLY 7XXXX	DWG. NO. 780274 REV	
	INTERPRET GEOMETRIC TOLERANCING PER: THIRD ANGLE GD&T	WEIGHT 2.448 LBS.	PARTS PER UNIT X	SCALE: SHEET 1 OF 1	

8 7 6 5 4 3 2 1

8 7 6 5 4 3 2 1

REVISIONS				
ZONE	REV.	DESCRIPTION	DATE	APPROVED
-	-	INITIAL RELEASE	-	-

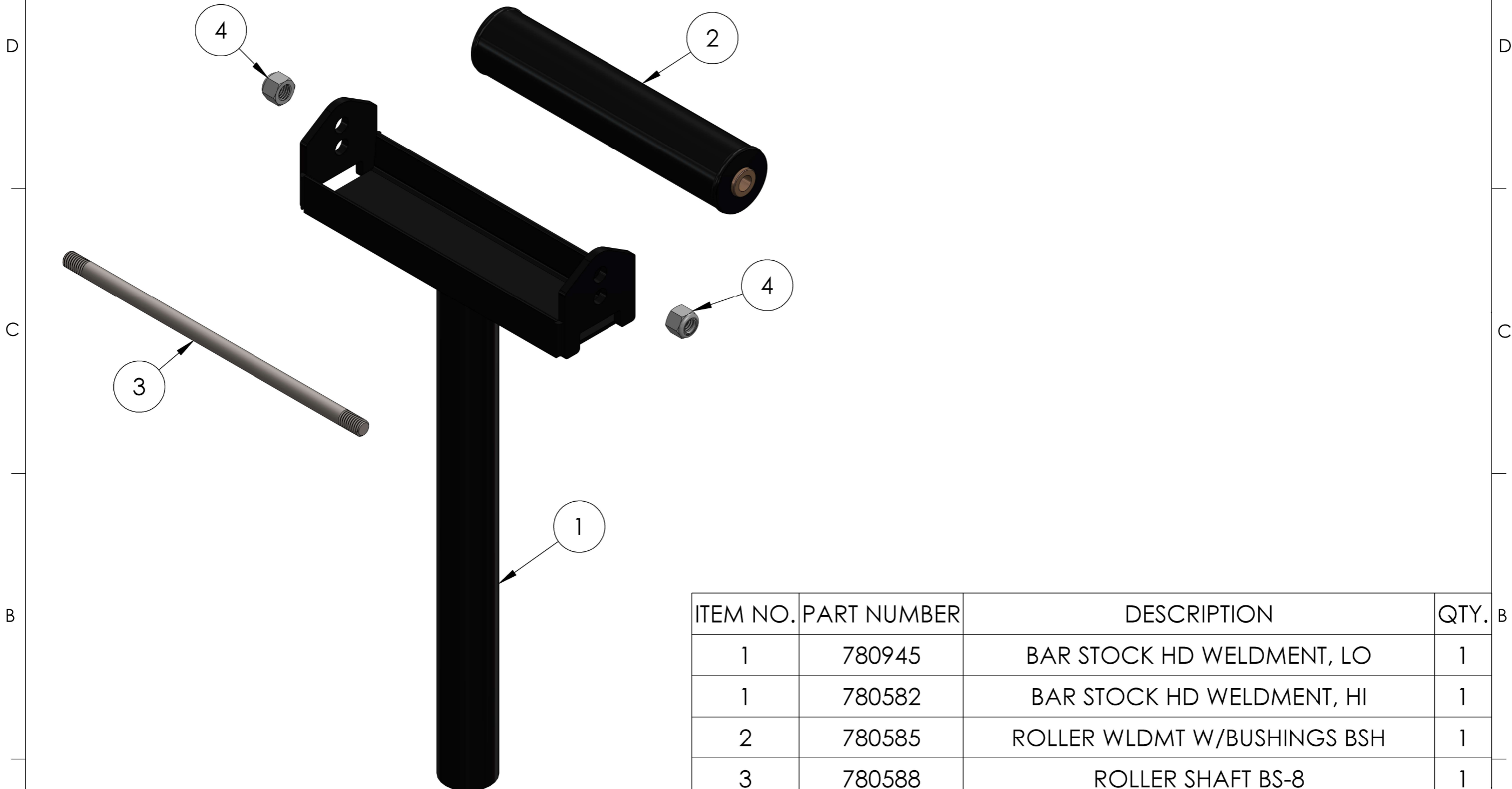

ITEM NO.	PART NUMBER	DESCRIPTION	QTY.
1	780945	BAR STOCK HD WELDMENT, LO	1
1	780582	BAR STOCK HD WELDMENT, HI	1
2	780585	ROLLER WLDMT W/BUSHINGS BSH	1
3	780588	ROLLER SHAFT BS-8	1
4	772357	NUT, INSERT LOCK 1/2 - 13	2

PROPRIETARY AND CONFIDENTIAL THE INFORMATION CONTAINED IN THIS DRAWING IS THE SOLE PROPERTY OF SUMNER MFG LLC. ANY REPRODUCTION IN PART OR AS A WHOLE WITHOUT THE WRITTEN PERMISSION OF SUMNER MFG LLC IS PROHIBITED.	UNLESS OTHERWISE SPECIFIED DIMENSIONS ARE IN INCHES. FABRICATION TOLERANCES: FRACTIONAL/WHOLE: ±1/32 ANGULAR: BEND ±1/2° MACHINE SHOP TOLERANCES: TWO PLACE DECIMAL: ±.03 THREE PLACE DECIMAL: ±.010	NOTES/COMMENTS: 1. BREAK ALL EDGES	NAME DATE SUMNER MFG LLC	
	MATERIAL AS NOTED	MATERIAL CODE 7XXXX	TITLE: DWG. NO. 780519 REV	
	FINISH DNU	NEXT ASSEMBLY 7XXXX		
	WEIGHT 8.541 LBS.	PARTS PER UNIT X	SCALE:	SHEET 1 OF 1
	INTERPRET GEOMETRIC TOLERANCING PER: THIRD ANGLE GD&T			

8 7 6 5 4 3 2 1

DO NOT SCALE DRAWING