

SIDES	BOTTOM
8 1/2" KNOCKOUTS	2 1/2" KNOCKOUTS
4 1/2"-3/4" MOON KNOCKOUTS	2 3/4" KNOCKOUTS
	1 Ground Hump
2 PCS 8-32x1/2 Screws Installed	
Material: Steel-0.0625"-G60 Galvanized	

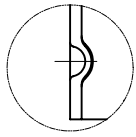

WELDING STYLE DETAIL VIEW D

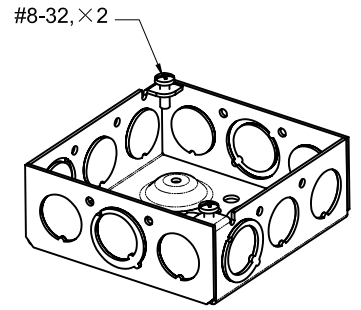
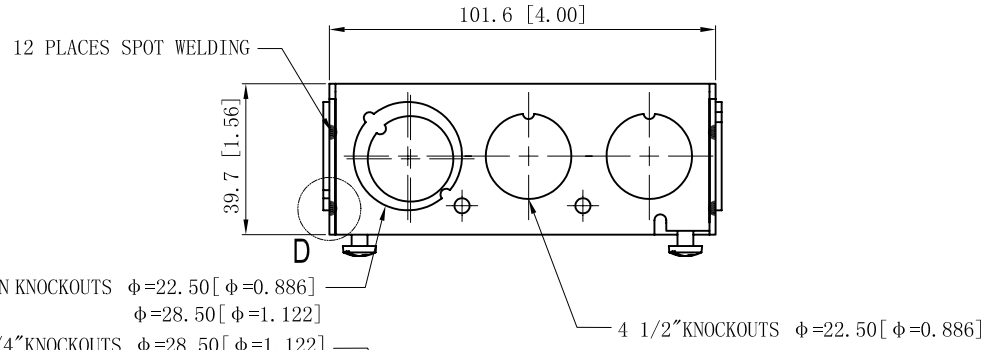
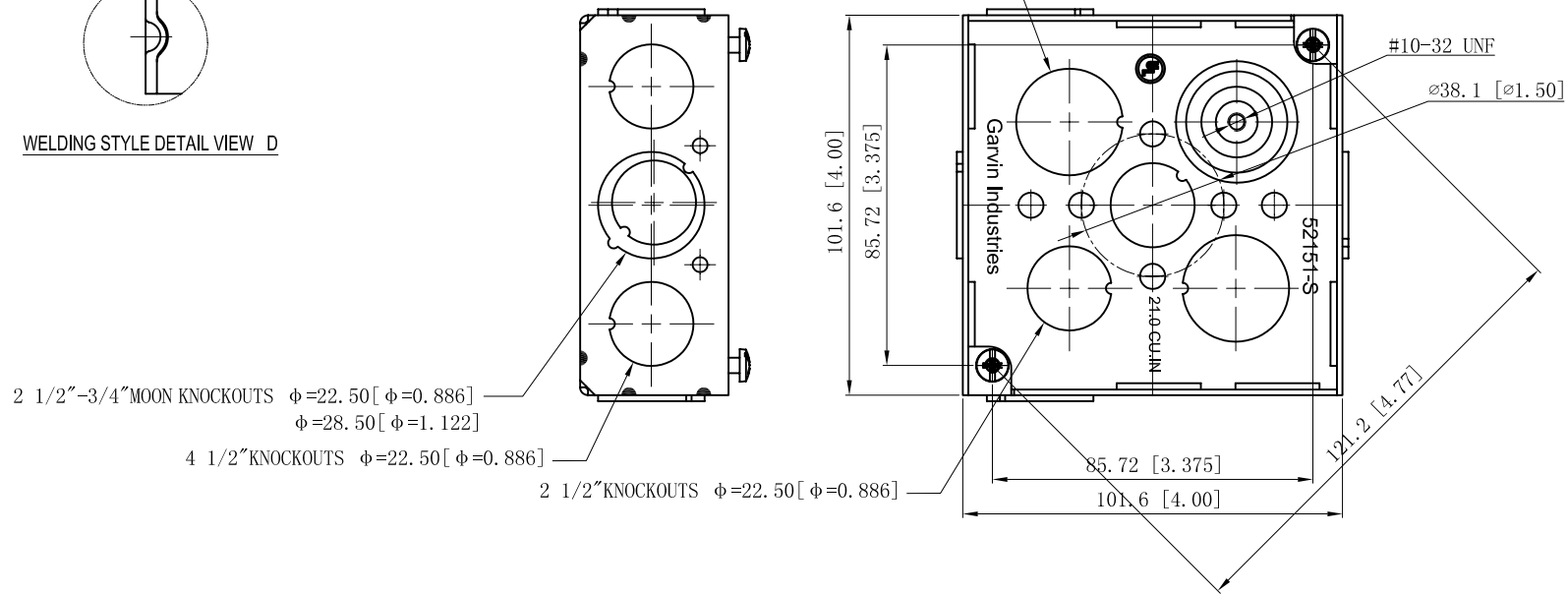

This data sheet is for reference only. GARVIN INDUSTRIES reserves the right to make changes to the design without prior notice.

DESCRIPTION
TRADE REFERENCE TERMS

STANDARD PACKING	<h1 style="text-align: center;">GARVIN INDUSTRIES</h1>		
50 PCS			
TITLE	4" SQUARE BOXES (1-1/2" DEEP)		
SIZE	DWG NO.	REV	
A4	52151-S	B	
DATA SHEET			