

SIDES	BOTTOM
2 PCS 8-32×1/2 Screws Installed	
Material:Steel-0.0625"-G60 Galvanized	

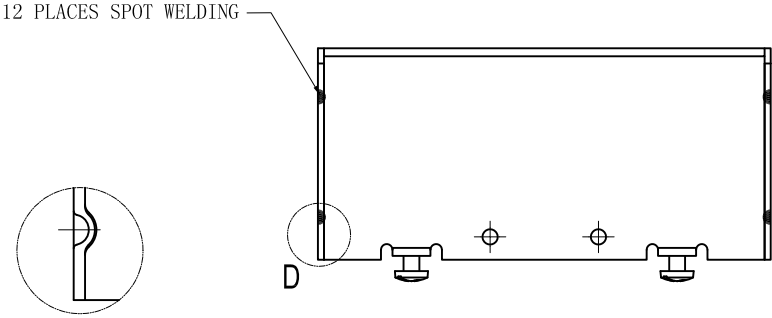

WELDING STYLE DETAIL VIEW D

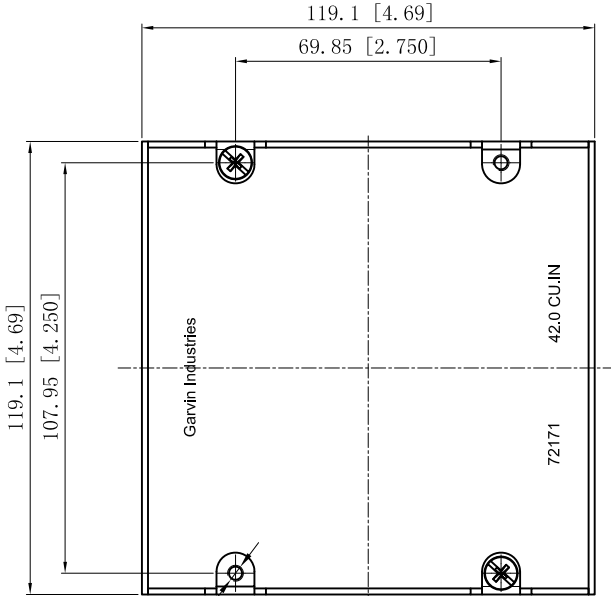
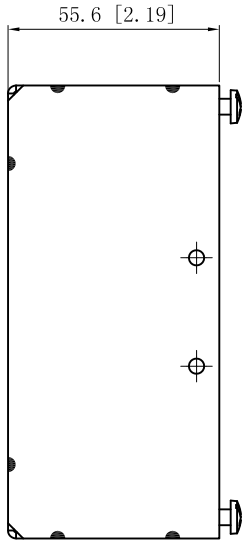

4-#8-32 UNC HOLE

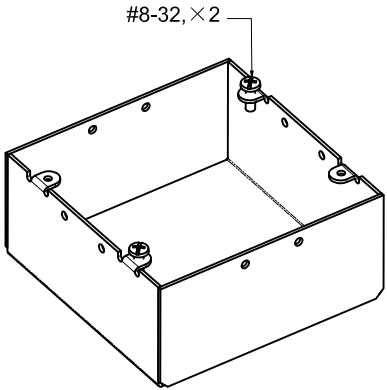

This data sheet is for reference only.GARVIN INDUSTRIES reserves the right to make changes to the design without prior notice.

DESCRIPTION
TRADE REFERENCE TERMS

STANDARD PACKING
25 PCS

GARVIN INDUSTRIES		
TITLE 4-11/16" SQUARE EXTENSION RINGS 2-1/8" DEEP		
SIZE A4	DWG NO. 72171-BLNKW	REV A
DATA SHEET		