

OPERATOR'S MANUAL

Fab-Mate

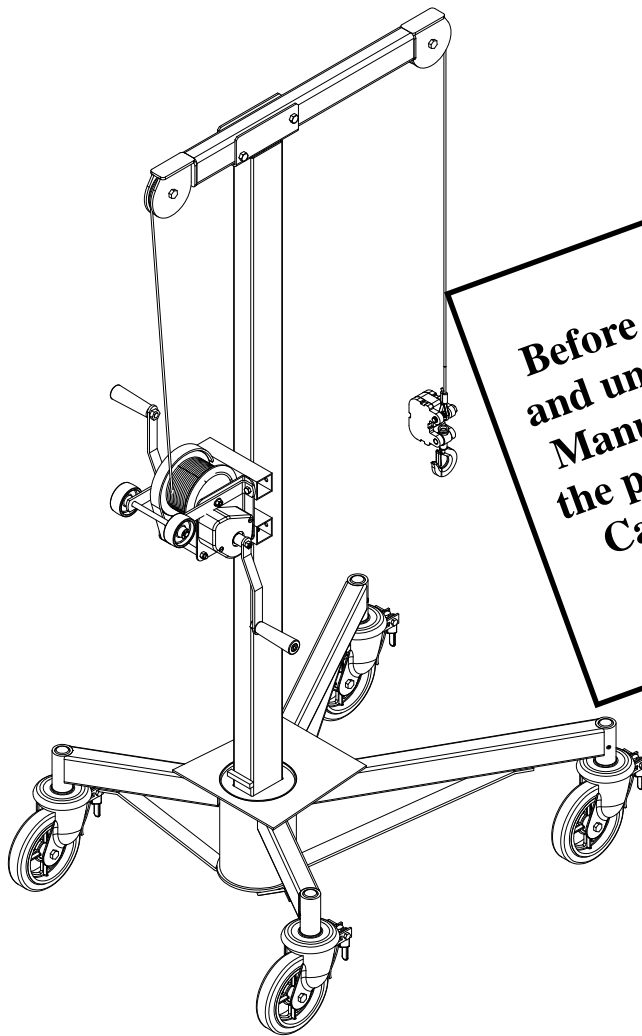

WARNING
Before operating this lift, read
and understand this Operator's
Manual. Become familiar with
the potential hazards of this lift.
Call Sumner if you have any
questions

SUMNER[®]

7514 Alabonson Rd. Houston, Texas 77088 281-999-6900 281-999-6966 (fax)

1721 Bishop St., Unit #4 Cambridge, Ontario N1T 1N5 519-623-2300 519-623-0744 (fax)

Haybrook Industrail Estate, Halesfield 9, Unit A6, Telford, Shropshire, UK TF7 4QW 011-44-1952-586517

INDEX

Operator Safety Instructions	3
Specifications	4
Assembly Instructions	5
Moving Fab-mate to work area (no load).....	5
Moving Fab-mate (with load).....	5
Attaching Lift Cable to Object	6
Elevating Load	6
Lowering Load.....	6
Removing Mast	6
Caster Brakes	6
Lift Diagram	7
Maintenance Instructions	8
Installing New Cable	8
Load Lifting Cable.....	8
Trouble Shooting	9
Maintenance Record	10

OWNER'S RESPONSIBILITIES

Throughout this publication, the words **WARNING**, **CAUTION** and **IMPORTANT** will be used to alert the user to special instructions concerning a particular operation that may be hazardous if performed incorrectly or carelessly.

OBSERVE THEM CAREFULLY !!

WARNING



Hazards or unsafe practices which could result in severe personal injury or death.

CAUTION



Hazards or unsafe practices which could result in minor personal injury, product or property damage.

IMPORTANT



Indicates information or instructions that are necessary for proper operation and/or maintenance.

OPERATOR SAFETY INSTRUCTIONS



IMPORTANT

Read and understand Operators Manual before using Fab-Mate



Inspect cable before use. Do not operate if cable is frayed, worn or damaged.



Never leave Fab-mate unattended with an elevated load.



Use only on solid level surface. Keep work area clear of clutter and debris.



Do not climb on Fab-mate or put side load on mast.



Test load balance before lifting. Do not exceed rated load capacity. Never use two Fab-mates to lift a load which exceeds the capacity of a single lift.



Do not operate during storms.

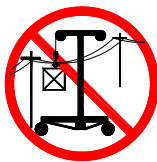

Stay clear of overhead wires and obstructions.



Never lift a load over the short legs unless a counter weight equal to the load is applied to the long legs.



Do not operate in gusty winds.



Do not pull or drag load.



Never allow anyone under an elevated load.

Do not move the Fab-mate by pulling on load line.

Do not use accessories with the Fab-mate that are not supplied by the manufacturer.

OPERATOR SAFETY INSTRUCTIONS (CONTINUED)



Wear proper clothing. Hard hat, safety shoes, and gloves should be worn as a precaution while operating this lift.

Avoid horseplay around equipment, and keep bystanders at a safe distance. Do not allow children to operate this unit and always keep them out of work areas.

SPECIFICATIONS

Model	Maximum Lifting Capacity*	Maximum Height
	1000 lbs (450 kg)	7 ft. (2.1 m)

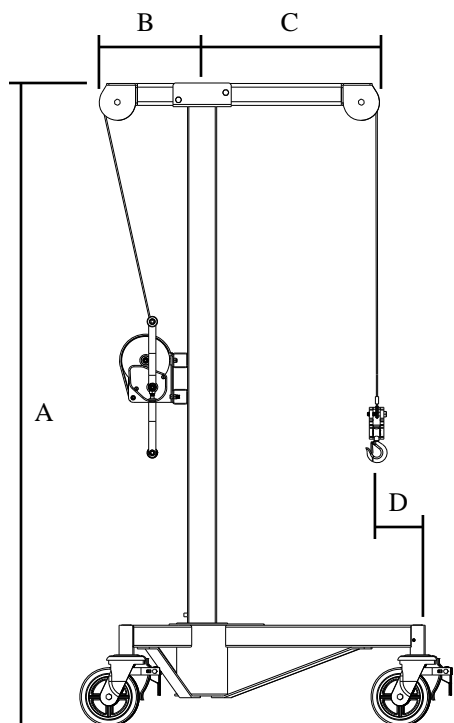

Model	A	B	C	D	Base Dimensions	Shipping Wt.
	88.5" 224 cm	14" 35.5 cm	24.5" 62 cm	7.5" 19 cm	31 x 40 79 x 101 cm	206 lb 93 kg

ASSEMBLY INSTRUCTIONS

1. Turn base upside down.
2. Insert the four casters into the base legs.
3. Secure the casters into the base by installing the four supplied setscrews into the base legs and then tighten with allen wrench. Ensure screw is tightened onto caster stem.
4. Turn base over and lock caster brakes.
5. Insert the Tee-Head into the bracket on top of the mast assembly and secure with the two supplied bolts. The long end of the Tee-head should be on the opposite side of the winch.
6. Insert mast assembly into base assembly socket with winch to rear of base, rear being the side of base with the shorter legs.
7. Lower the lift cable so the end of the cable can be reached by operator.
8. Attach counterweight and line shackle directly to loop on end of lift cable.

WARNING



Operators should be thoroughly familiar with the preceding safety precautions before attempting to operate this equipment.

OPERATING PROCEDURE

1. UNPACKING THE LIFT

The winch handles have been placed in the stored position at the time of shipment.

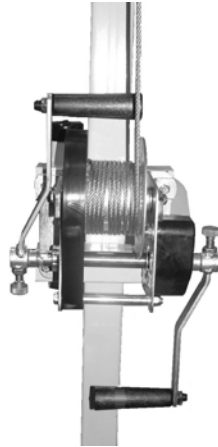

To place the winch handles in the operating position, pull up on the locking pin and slide the handle off of the winch shaft. Rotate the handle assembly around so that the black plastic grip is facing away from the winch. While pulling up on the locking pin, slide the handle back on to the winch shaft. Repeat this procedure for the other handle

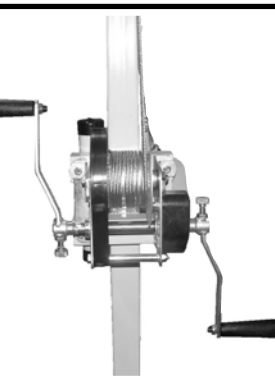
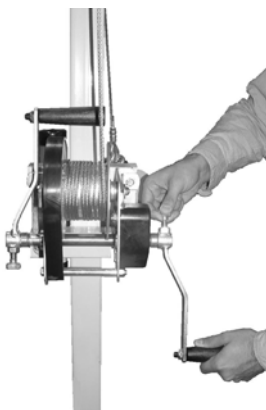

WARNING

When properly installed, the winch handles should be mounted 180 degrees apart. Do not attempt to raise or lower a load with the handles mounted in any other manner.

2. MOVING FAB-MATE TO WORK AREA (NO LOAD)

1. The load line shackle should be attached to winch mount bracket prior to transporting unit to prevent the cable from swinging and striking operator or bystanders.
2. Attach winch handles to both sides of winch, which will allow them to be used as a handlebar to steer the unit.
3. Release caster brakes.
4. Grasp winch handles and make a forward "S" motion to align casters for forward movement to work area.



WARNING

Fab-mate should only be operated on level and smooth surfaces to avoid tipping and possibility of operator injury.

3. MOVING FAB-MATE TO WORK AREA (WITH LOAD)

1. When the Fab-Mate is used to transport a load, the load should be placed on the base legs for positive control of the lift.
2. The loaded Fab-Mate should only be moved in the forward direction, whenever possible.
3. Repeat steps 2, 3 and 4 from previous section.

1. Turn handle on winch clockwise to elevate.
2. Never allow lift cable loop, Counter Weight, or line shackle to contact “Tee Head” while elevating mast. Continued cranking in this condition will cause “Tee Head” to bend.

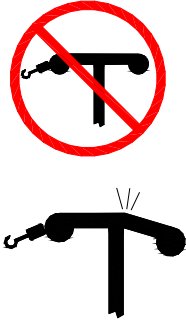

4. Attaching Lift Cable to Object

1. Lower lift line to load by rotating the winch handles counter clockwise.
2. Lower the hook until the cable is long enough to securely attach to the load.

Note: Secure load line using approved rigging practices and equipment only.



WARNING
Always lift load slightly to check rigging and balance before elevating.

5. Elevating Load

1. Raise the load by turning the winch handles in a clockwise direction.



WARNING
Never allow anyone under an elevated load.

6. Lowering Load

1. Lower the load by turning the winch handles in a counterclockwise direction.

7. Removing Mast

Note: Caster brakes should always be locked when removing mast.

1. Place crowbar under pry tab and raise mast from base until the locating ring rests on top of the base.
2. Remove mast from the base.

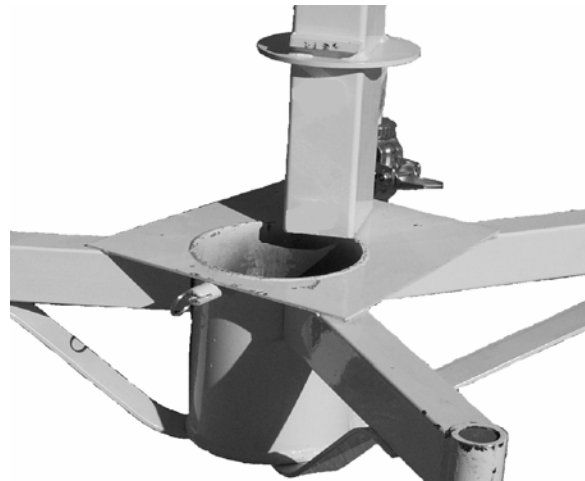
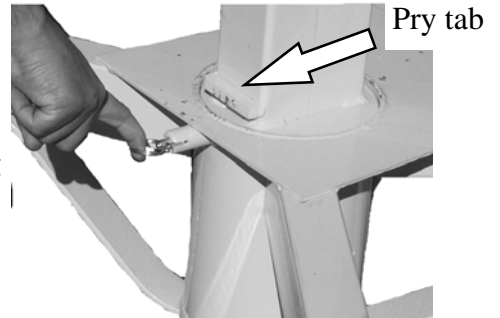

8. Caster Brakes



1. Set brake by pressing down on brake lever as shown.
2. Release brake by lifting up on brake lever.

9. Lift Diagram

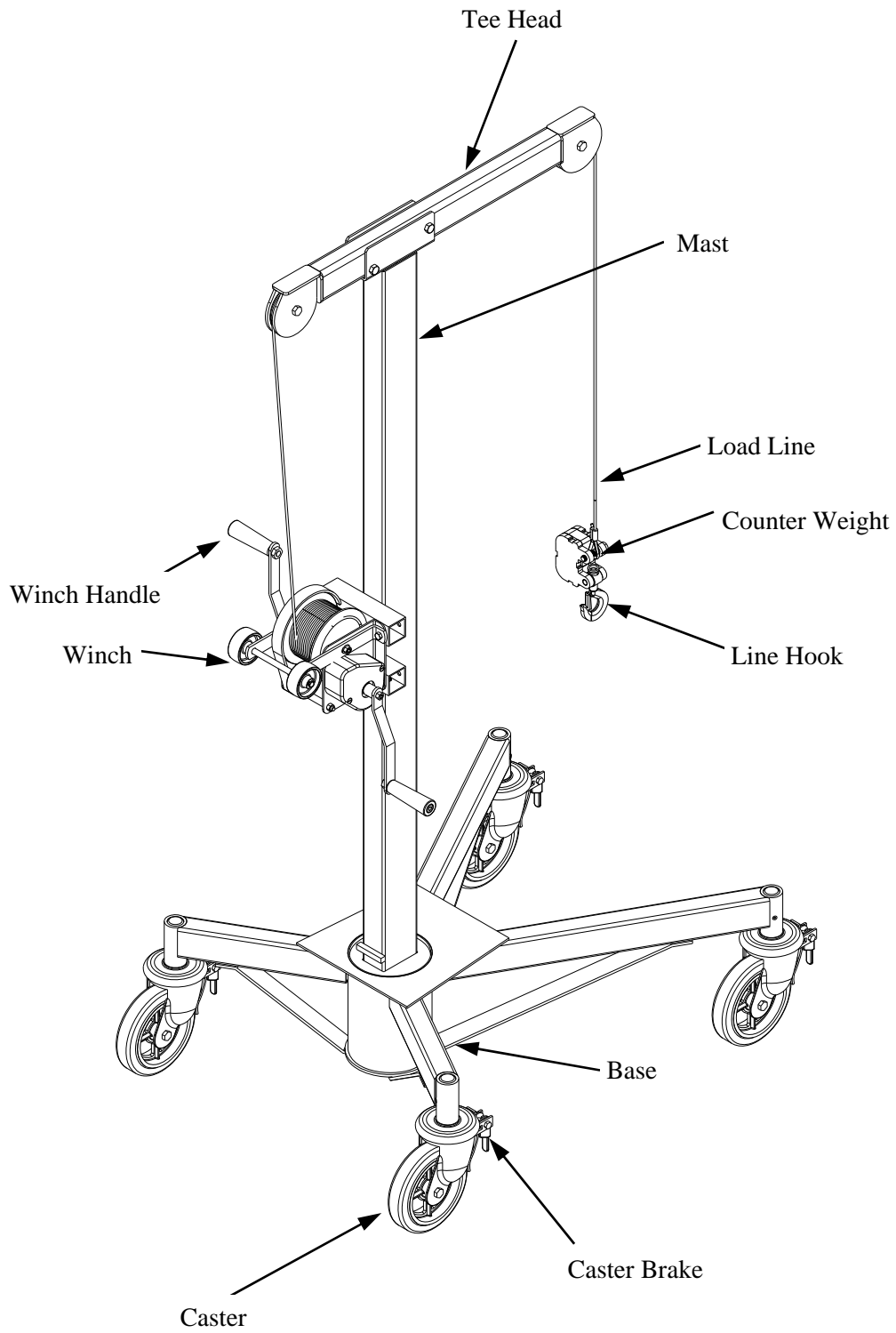

MAINTENANCE INSTRUCTIONS

Before each use:

1. Inspect the cable for kinks and frays. If kinked or more than 3 wire strands are broken (small wires) do not use the lift until the cable has been replaced.
2. Make certain winch operates freely and cable is not tangled on the winch drum.
3. Inspect mast, legs, and base for bends.
4. Make sure caster wheels move freely.

Recommended Inspection Every 6 Months:

1. Inspect cable for frays and kinks (see point 1 above)
2. Make certain winch works freely and that there are no loose or damaged parts.

Winch Maintenance:

1. Refer to the winch assembly drawings in this Operators Manual.
2. Be sure that the winch cover is on the winch.
3. Check ratchet dog and brake ratchet for wear. If any wear is visible, replace the part.
4. Inspect gear teeth for wear. If there is no sign of visible wear, brush teeth with 50-wt. Motor oil.
5. For proper brake adjustment see "Troubleshooting" section on page 9.

Replacing the Cables:

A. Load Lifting Line

1. Lay Fab-Mate across supports with the winch facing up.
2. Remove the gear cover.
3. Disengage load ratchet dog and pull wire rope off of drum.

4. Loosen set screw on drum and pull wire rope out of keeper.
5. Pull Load Line out through front of Tee head.
6. Reverse for installing new Load Line.

General Maintenance:

1. Check winch handle for wear or bends.
2. Examine all bolts and nuts to be sure they are tight.
3. Legs, braces and base should be dent free and damage free.
4. Check pulley housings for damage (indentations) which can restrict the rotation of the pulleys.
5. Make sure all lines are seated in all pulleys and that pulleys rotate without obstruction.
7. Make sure caster wheels rotate freely and are undamaged.

**WARNING**

Modifying the Fab-Mate in any way can cause injury or death!

**WARNING**

Replace all worn or damage parts only with Sumner parts.

TROUBLESHOOTING

PROBLEM	CAUSE	SOLUTION
Fab-Mate not holding the load.	Winch Brakes need adjusting.	See below
	Brake pads are worn.	Replace Brake pads.
	Ratchet Dog or Brake Ratchet are worn.	Replace the Ratchet Dog and/or Brake Ratchet
	Ratchet Spring is broken or worn.	Replace the Brake Ratchet Spring.
The winch is hard to crank down	The brake is over-engaged.	See illustration and instructions below.
	The brake will not disengage.	See illustration and instructions below.
	The idler gear is displaced.	Make sure that the idler rotates freely and the teeth on the idler gear are now worn.
You have serviced the winch and now the brake does not work at all.	The brake ratchet or ratchet dog are not installed correctly.	

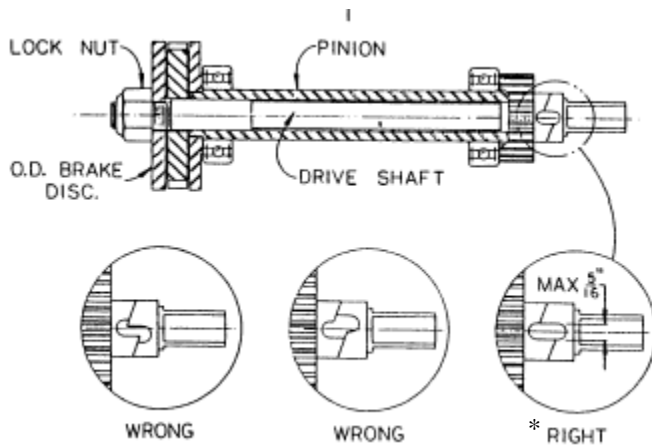
**Important**

For proper adjustments on the MX winch, the pinion and drive shaft must be in the positions shown when the lock nut is tightened against the O.D. brake disc to 15 ft-lbs.

* Correct alignment is only visible when load is applied to lift.

MAINTENANCE RECORD

Lift Model Number _____

Lift Serial Number _____

Service Performed:

Action

Date

Action

Date

Action

Date

Action

Date

Action

Date

Action

Date

Action

Date

Action

Date

Action

Date

Action

Date

Action

Date

Action

Date

Action

Date