

SIDES	BOTTOM
2 PCS 8-32×1/2 Screws Installed	
1 PCS #1/4-20×7/8 Screws Installed	
2 PCS #10-32×1 Screws Installed	
Material:Steel-0.0625"-G60 Galvanized	

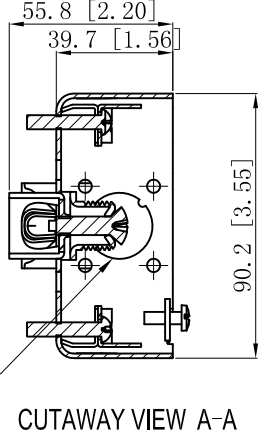
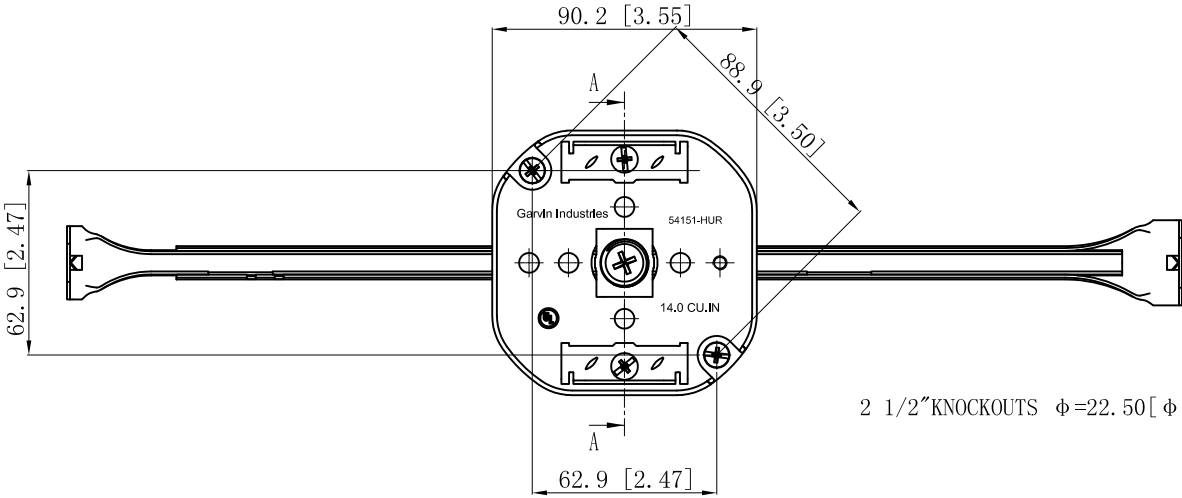
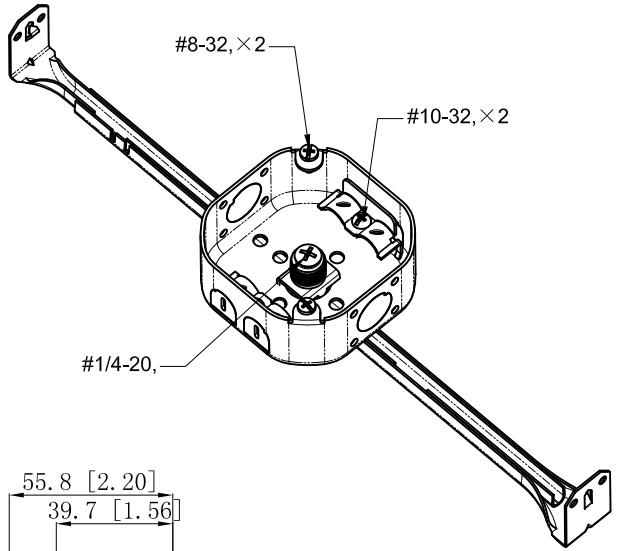
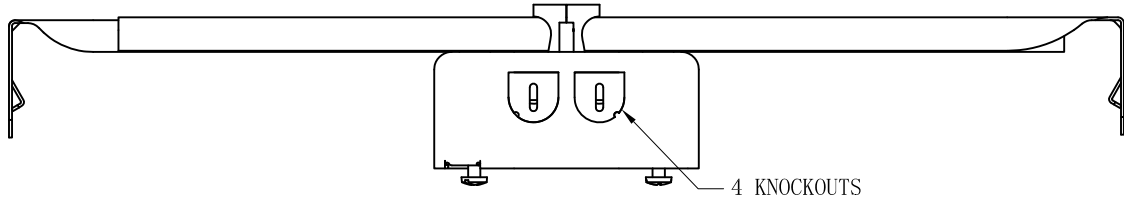

This data sheet is for reference only. GARVIN INDUSTRIES reserves the right to make changes to the design without prior notice.

DESCRIPTION
TRADE REFERENCE TERMS

STANDARD PACKING
25 PCS

<h1 style="margin: 0;">GARVIN INDUSTRIES</h1>		
<h2 style="margin: 0;">4" OCTAGON BOXES 1-1/2" DEEP</h2>		
TITLE	54151-HUR	REV A
SIZE A4	DWG NO.	DATA SHEET