



Southwire™

DIE-CAST ALUMINUM COVERS DOUBLE GANG COVERS DUPLEX-GFCI

FEATURES

- Die cast zinc cover with a spring loaded lid
- Weather seal gasket to keep moisture out
- Superior commercial quality die cast metal construction
- Installation instructions included
- Gray

APPLICATIONS

- UL listed for wet locations
- For use with double gang outdoor device box

STANDARD MATERIAL

- Precision die cast zinc

STANDARD FINISH

- Premium powder coat finish



WCV2DUPGFI



UL® Listed and 2011 NEC® and
NEMA® 3R Compliant

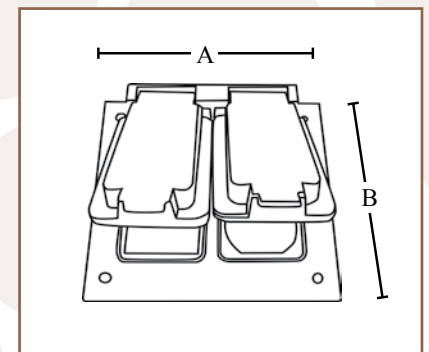

PART #	MASTER QTY.	WEIGHT/ CASE (LBS.)	A	B
WCV2DUPGFI	25	12	4.54"	4.54"

Rev. 0, 06/23

**BUILT FOR DURABILITY.
BUILT FOR RELIABILITY.
BUILT FOR WORK.™**

1-855-798-6657 | SOUTHWIRE.COM

©2023 Southwire Company, LLC. All rights reserved.
*Registered Trademark & ™Trademark of Southwire Company, LLC.