



# Southwire™

## RIGID CONDUIT BODIES

### THREADED TB TYPE - MALLEABLE IRON

#### FEATURES

- NPT tapered hubs

#### APPLICATION

- Provides access to conductors for pulling, splicing and maintenance

#### STANDARD MATERIAL

- Malleable iron

#### STANDARD FINISH

- Zinc plated, aluminum enameled

#### CERTIFICATIONS

- UL Standard: UL 514A
- Fed. Spec: W-C-586D
- NEMA: FB 1



TB1M

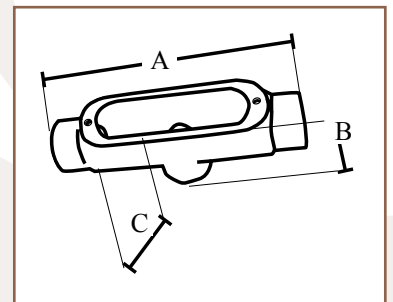

PART #	SIZE	WIRE SIZE		INTERNAL VOLUME (IN <sup>3</sup> )	MASTER QTY.	WEIGHT/CASE (LBS.)	A	B	C
		MAX. NUMBER	MAX. SIZE						
TB1M	1/2"	---	---	5.6	10	10	5.25"	1.9375"	1.9375"
TB2M	3/4"	3	6 AWG	9.5	10	6	6.0625"	1.5625"	1.5625"
TB3M	1"	3	4 AWG	15	5	20	7.125"	1.8125"	1.8125"
TB4M	1-1/4"	3	2 AWG	33	5	19	9.3125"	2.4375"	3.75"
TB5M	1-1/2"	3	1 AWG	36	2	20	9.3125"	2.4375"	3.75"
TB6M	2"	3	2/0 AWG	75	1	13	11.8125"	3.8125"	4.125"

Rev. 0, 03/23

**BUILT FOR DURABILITY.  
BUILT FOR RELIABILITY.  
BUILT FOR WORK.™**

1-855-798-6657 | SOUTHWIRE.COM

©2023 Southwire Company, LLC. All rights reserved.  
\*Registered Trademark & ™Trademark of Southwire Company, LLC.