

SIDES	BOTTOM
12 3/4" KNOCKOUTS	
2 PCS 8-32X1/2 Screws Installed	
Material: Steel-0.0625"-G60 Galvanized	

12 PLACES SPOT WELDING

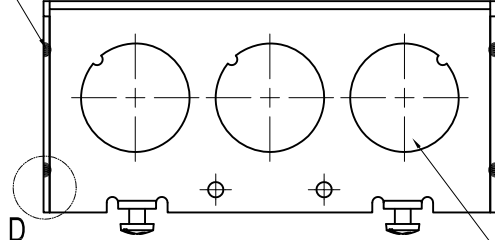

WELDING STYLE DETAIL VIEW D



6 3/4" KNOCKOUTS $\phi=28.5$ [$\phi=1.122$]

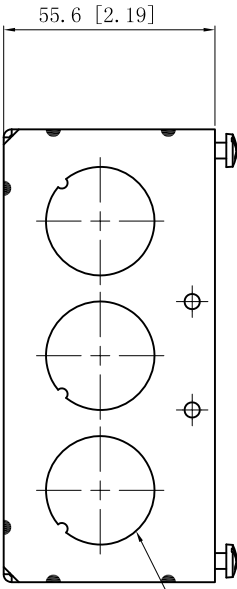

6 3/4" KNOCKOUTS $\phi=28.5$ [$\phi=1.122$]

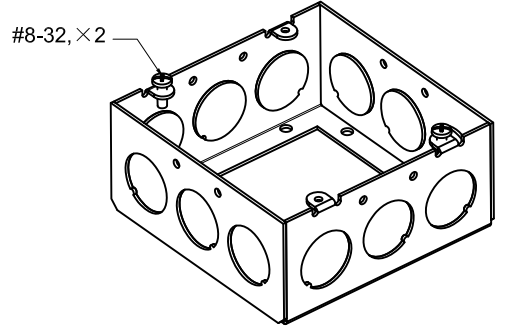
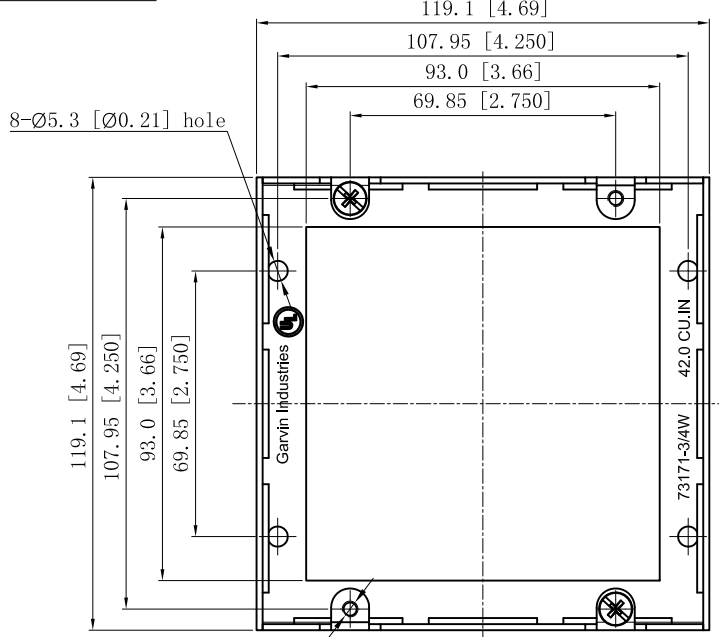

#8-32, X2

DESCRIPTION
TRADE REFERENCE TERMS

This data sheet is for reference only. GARVIN INDUSTRIES reserves the right to make changes to the design without prior notice.

STANDARD PACKING	GARVIN INDUSTRIES		
	TITLE 4-11/16" SQUARE EXTENSION RINGS 2-1/8" DEEP		
25 PCS	SIZE	DWG NO.	REV
	A4	73171-3/4W	A
DATA SHEET			