

OPERATOR'S MANUAL

Adjust-A-Flange

WARNING
Before operating this tool, read
and understand this Operator's
Manual. Become familiar with the
potential hazards of this tool.
Call Sumner if you have any
questions

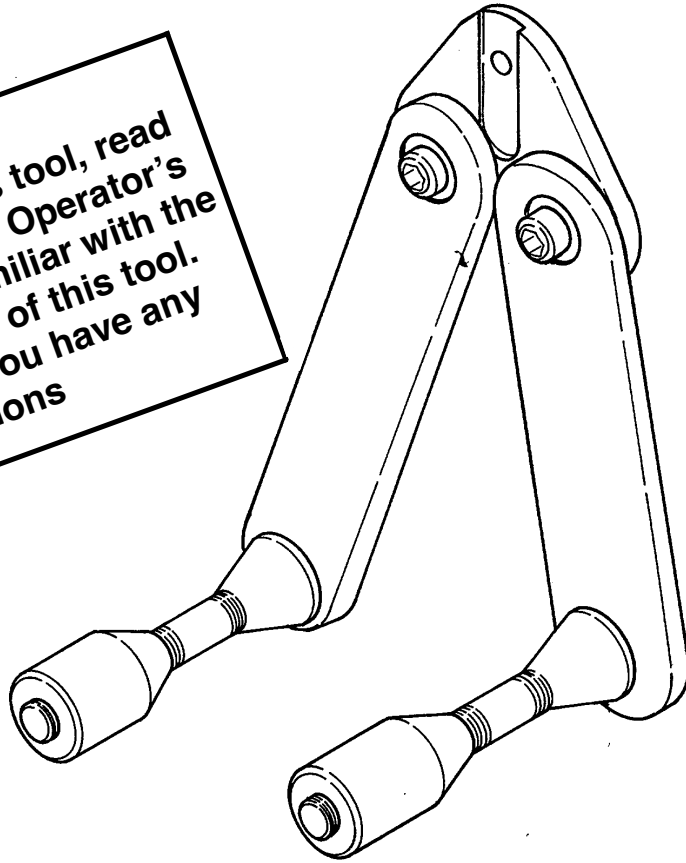

SUMNER

USA
7514 Alabonson Rd.
Houston, TX 77088
p: 281-999-6900
f: 281-999-6966

OWNER'S RESPONSIBILITIES

Throughout this publication, the words **WARNING**, **CAUTION** and **IMPORTANT** will be used to alert the user to special instructions concerning a particular operation that may be hazardous if performed incorrectly or carelessly.

OBSERVE THEM CAREFULLY !!

These "Safety Alerts" alone cannot eliminate the hazards that they signal. Strict compliance to these special instructions while performing the intended operation, plus "common sense" operation are a major accident prevention measures.

WARNING



Hazards or unsafe practices which could result in severe personal injury or death.

CAUTION



Hazards or unsafe practices which could result in minor personal injury, product or property damage.

IMPORTANT



Indicates information or instructions that are necessary for proper operation and/or maintenance.

OPERATOR SAFETY INSTRUCTIONS

IMPORTANT



Read and understand Operators Manual before using Adjust-A-Flange

Become familiar with the unit's operations, applications and limitations. Always contact the factory if in doubt. Be particularly aware of its specific hazards. Additional copies of this manual are available at no charge from Sumner Manufacturing Co. Inc.

Although this clamp is manufactured for safe, dependable operation, it is impossible to anticipate those combinations of circumstances, which could result in an accident. The following instructions are recommended for safe operation of this unit.

WARNING



Modifying the Adjust-A-Flange in any way can cause injury or death.

Do not use accessories with the Adjust-A-Flange that are not supplied or recommended by the manufacturer.

The Adjust-a-Flange is used to lift and positioning steel flanges in a welding application.

WARNING



Using the Adjust-a-Flange to hoist both pipe and fittings may cause injury.

Always keep floor in work area clear of clutter.

Operate from safe position.

Prior to each use, check all parts to ensure that they are in proper operating condition.

IMPORTANT



Make any necessary repairs before attempting to operate the tool. Use only Sumner parts for repairs.



Wear proper clothing. Hard hat, safety shoes, and eye protection should be worn as a precaution while operating this equipment.

Avoid horseplay around equipment, and keep bystanders at a safe distance. Do not allow children to operate this unit and always keep them out of work areas.

Keep work area clean.

Always keep floor in work area clear of clutter.

Keep balance and proper footing at all times.

Keep alert

OPERATING INSTRUCTIONS

1. The Adjust-A-Flange is intended to be used with a Sumner Roust-A-Bout, Fabmate or an overhead lifting device. Make sure the hoist's load capacity is 1000 lb (455 kg) or greater.
2. The intent of an Adjust-A-Flange is to level flanges using the "two holing" process prior to welding to pipes.
3. Attach the Adjust-A-Flange to your overhead lifting device. A $5/16"$ (8 mm) diameter hole is provided as an attachment point.
4. Remove the Adjust-A-Flange nuts from the screws.
5. Slide the flange onto the Adjust-A-Fit, ensuring each screw passes completely through a bolt hole. The face of the flange should be adjacent to the Adjust-A-Fit.
6. Replace the Adjust-A-Flange nuts ensuring that the screw is not less than 2 threads from the back of the nut. If the screw is more than 2 threads deep into the nut, the flange is too thick for the Adjust-A-Flange to be used safely.

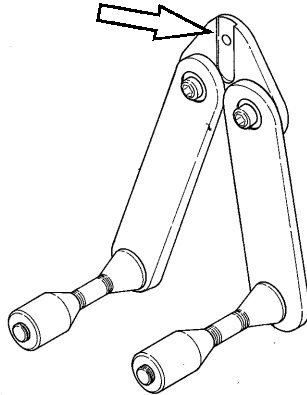

7. Place a level on top of the two Adjust-A-Flange nuts. It should indicate level.
8. If the flange is not level, remove one of the Adjust-A-Flange nuts, spread the arms open further, and place the screw into the next closest bolt hole.
9. Repeat step 7.

Using the Adjust-A-Flange with an Adjust-A-Fit

The Adjust-A-Flange can also be used in conjunction with an Adjust-A-Fit to allow for leveling in two planes.

For the proper orientation of the two units used in tandem, see figure below.

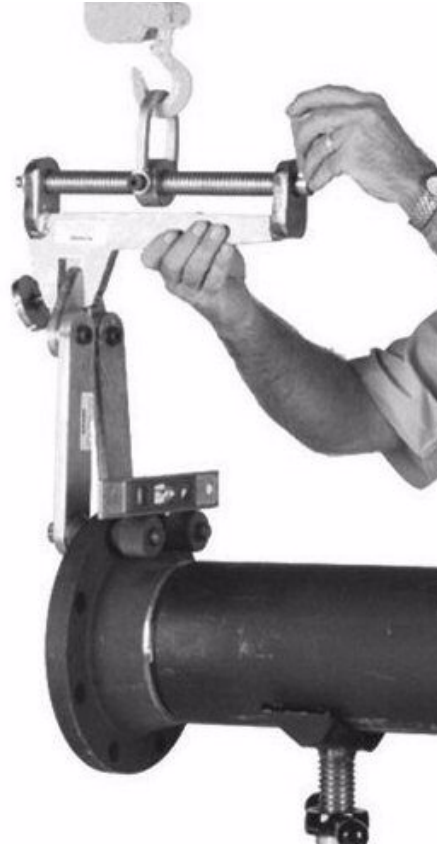

CAUTION



Never use the Adjust-A-Flange if the screw is deeper than 2 threads from the back of the nut.

1. Attach the Adjust-A-Flange to the Adjust-A-Fit ensuring the set screw on the Adjust-A-Fit engages the 5/16" (8 mm) hole and that the fingers of the Adjust-A-Fit sit firmly into the recess on the body of the Adjust-A-Flange.
2. The set screw will not pass through the hole.
3. Attach the two tools to your overhead lifting device.
4. Follow Operating Instructions 1 thru 9 from Page 4.

CAUTION



Read the Adjust-A-Fit Operators Manual prior to using in conjunction with the Adjust-A-Flange.

CAUTION



Never allow the weight of the flange and Adjust-A-Flange together to exceed the capacity of the Adjust-A-Fit.

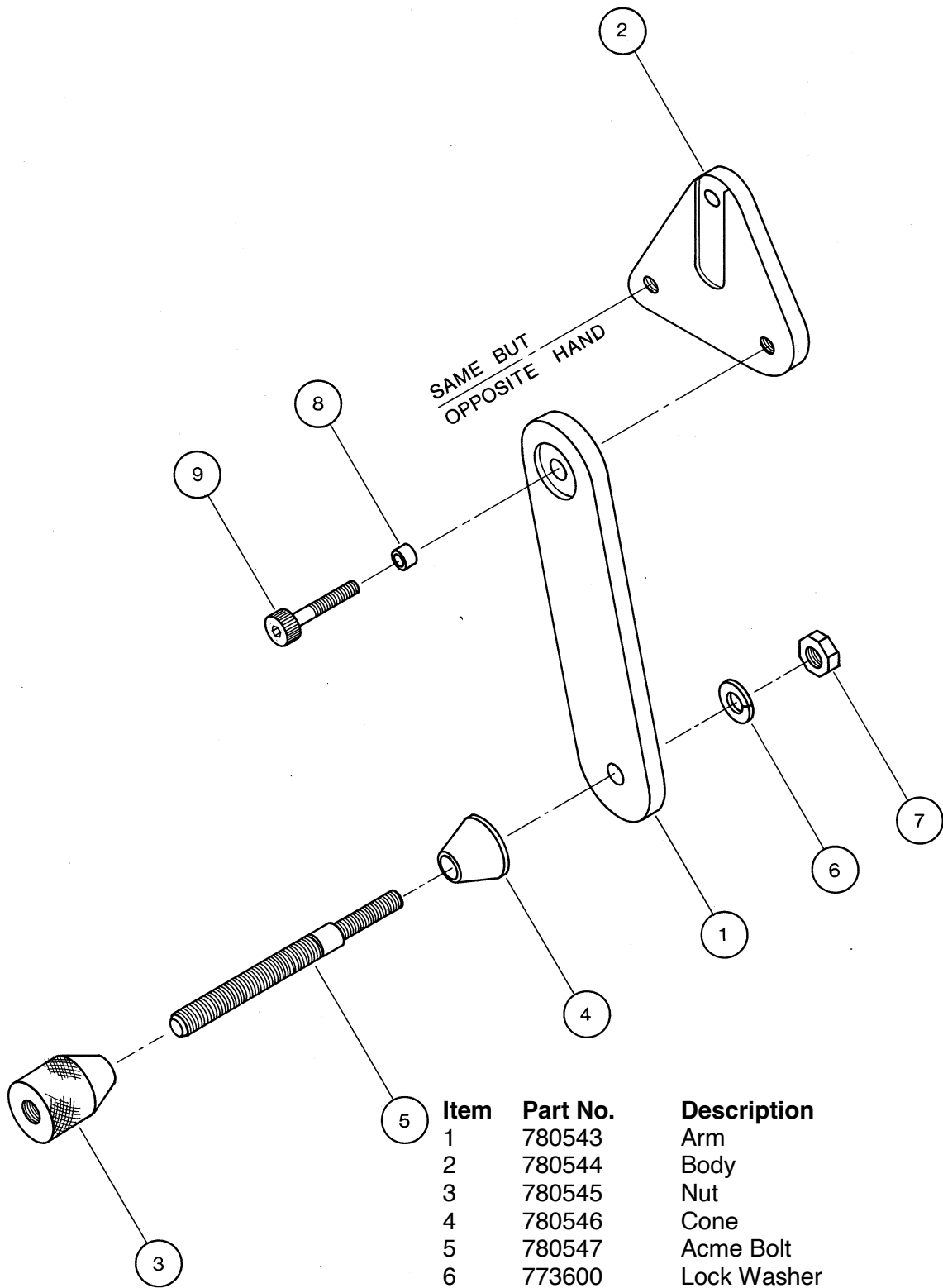

Item	Part No.	Description	Qty
1	780543	Arm	2
2	780544	Body	1
3	780545	Nut	2
4	780546	Cone	2
5	780547	Acme Bolt	2
6	773600	Lock Washer	2
7	772150	Hex Nut, 9/16-18	2
8	775040	Bushing	2
9	771350	Shoulder Screw 1/2 x 1/2	2