

LED LINEAR T8-BALLAST BYPASS

2' SINGLE-ENDED

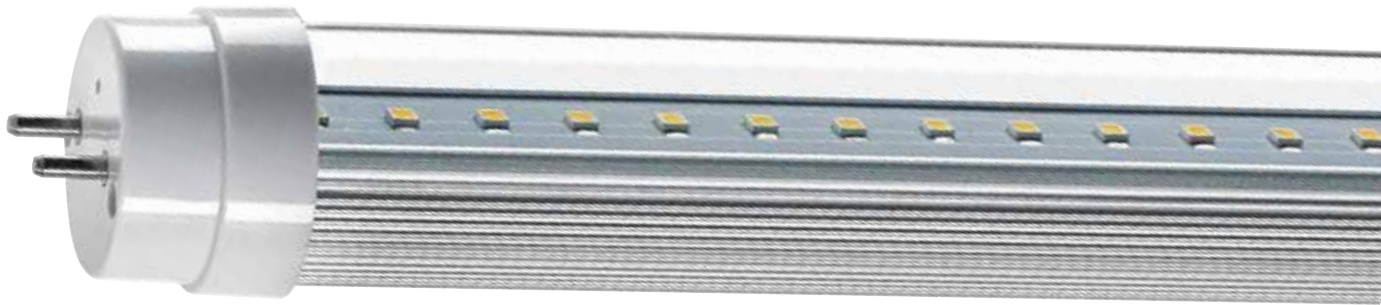

SUGGESTED APPLICATIONS

- Office, retail, hospitality, warehouse

FEATURES

- Bypass single-end connection*
- Polycarbonate lens and aluminum heat sink
- Non-shunted lampholder included
- Extremely long life and energy efficient
- No mercury
- Easy and safe replacement for fluorescent T8 systems

*Specifications are subject to change without prior notice.
* Requires non-shunted lampholder for single-end connection*



LED LINEAR T8-BALLAST BYPASS 2' SINGLE-ENDED

GENERAL SPECIFICATIONS

- 10W
- 120-277V
- 82 CRI
- 50,000 Average Rated Life
- 130° Beam angle
- -20°C to 40°C Ambient temperature
- Polycarbonate tube construction

ITEM SPECIFICATIONS / ORDER INFO

Catalog Number	Product Code	UPC Code	Color Temp	Wattage	Lumens	LPW	Case Qty
L2T8B/835/10C/SE-75	71036	751338015685	3500K	10W	1,160	116	1/20
L2T8B/840/10C/SE-75	71037	751338015692	4000K	10W	1,180	118	1/20
L2T8B/850/10C/SE-75	71038	751338015708	5000K	10W	1,200	120	1/20
L2T8B/860/10C/SE-75	71039	751338015746	6000K	10W	1,220	122	1/20

This device complies with Part 15 of the FCC Rules. Operation is subject to the following two conditions: (1) this device may not cause harmful interference, and (2) this device must accept any interference received, including interference that may cause undesired operation.

* Requires non-shunted lampholder for single-end connection

WARNING: Some products included in this specification sheet may be subject to the warning requirements of California's Proposition 65. Please refer to your product packaging for more information.

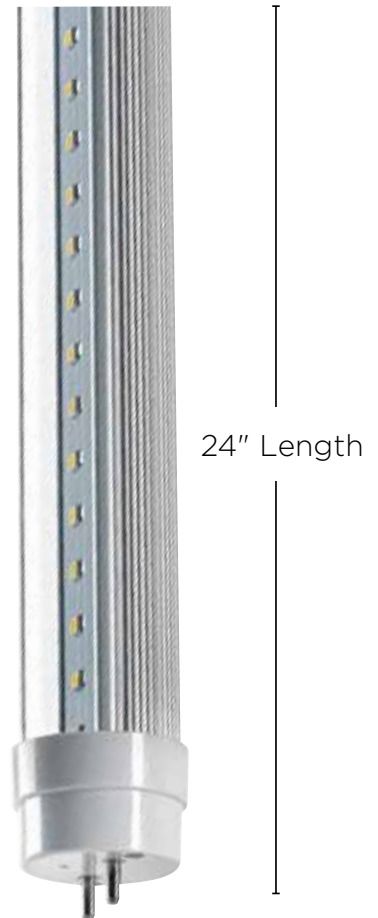
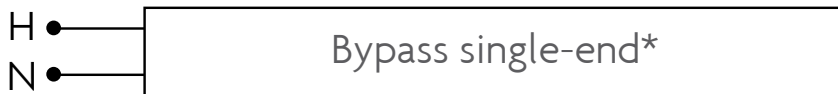

G13 Bi-pin Base