

# GRASSHOPPER ASSEMBLY

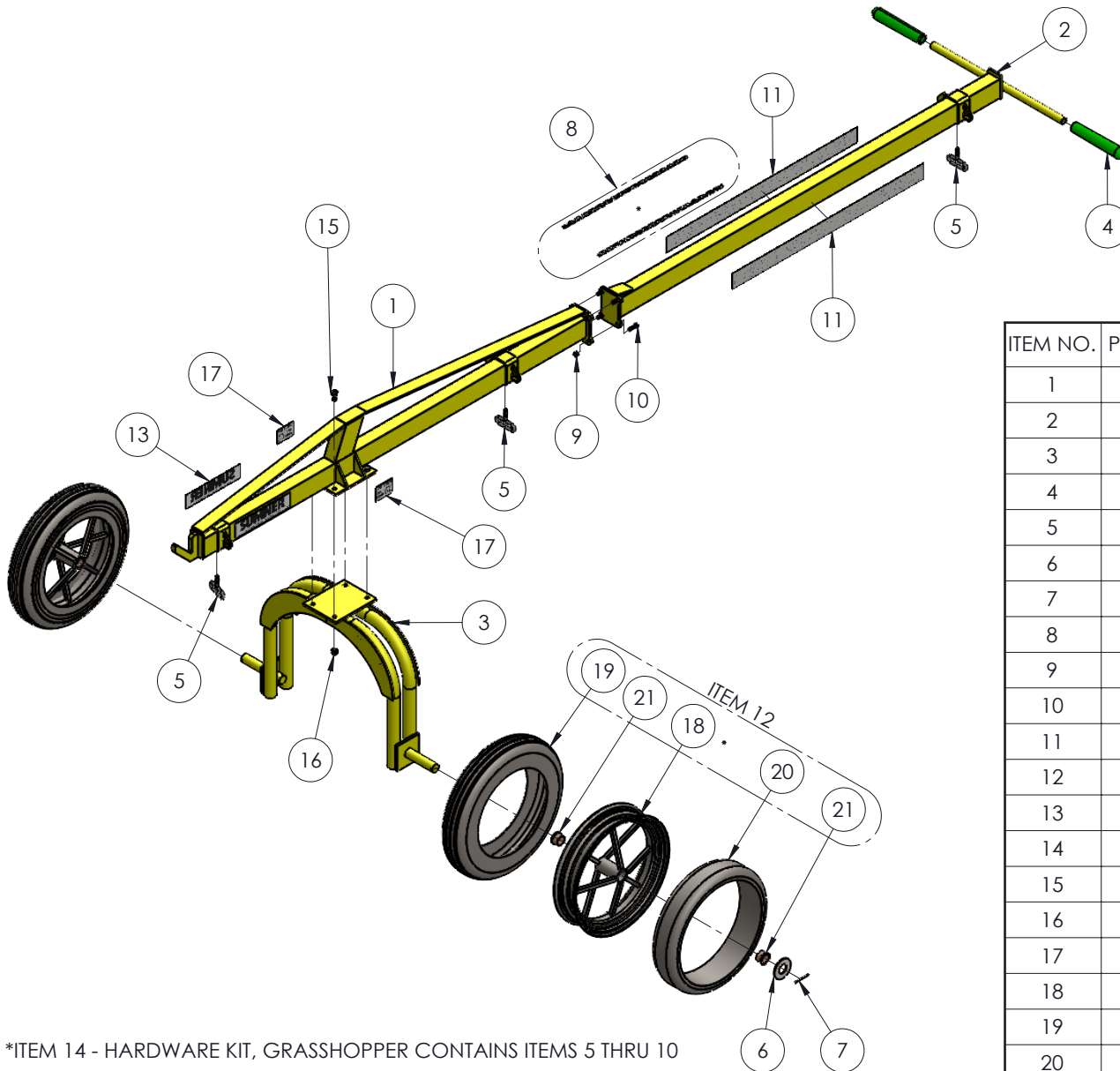

ITEM NO.	PART NUMBER	DESCRIPTION	QTY.
1	781028	REAR BEAM WELDMNT	1
2	781029	HANDLE WELDMT, GRASSHOPPER	1
3	781030	LEG WELDMNT, GRASSHOPPER	1
4	779909	GRAB ON GRIPS	2
5	780552	SETSCREW C-110W	3
6	773200	WASHER, FLAT 1-1/4	2
7	774050	PIN, COTTER BRASS 3/16 X 2	2
8	780530	CHAIN SET GRASSHOPPER GH-31	2
9	772355	NUT, INSERT LOCK 3/8-16	4
10	771060	SCREW, HHC 3/8-16X1.25"LN	4
11	778949	DECAL, GH LETTERING	2
12	780521	WHEEL ASSY GH-16 (NEW STYLE 16IN)	2
13	778904	LABEL SUMNER (RAB)	2
14	780352	HARDWARE KIT, GRASSHOPPER	1
15	771125	SCREW,HHC 1/2-13 X 1"	4
16	772357	NUT, INSERT LOCK 1/2 - 13"	4
17	778928	LABEL, CAUTION LOAD LIMIT 2000 LBS	2
18	781046	GH WHEEL WELDMNT 16"	2
19	779120	TIRE, GH-2 400-16 IMP RIB	2
20	779121	TUBE GH-2A 400-16 IMP RIB (NEW)	2
21	775009	BUSH, BZ FL 1-1/4 X 1-1/2 X 3/4	4

\*ITEM 14 - HARDWARE KIT, GRASSHOPPER CONTAINS ITEMS 5 THRU 10