



Southwire™

MOGUL CONDUIT BODIES WITH COVER AND GASKET

LR TYPE - HOT DIP GALVANIZED - MALLEABLE IRON

FEATURES

- c(UL)us wet locations
- Threaded NPT tapered hubs for Rigid and IMC conduit
- Smooth and round integral hub bushings protect conductor insulation
- Access to wiring for maintenance and future changes
- Assembled with raised cover, gasket and stainless steel cover screws

APPLICATION

- Use to pull straight or 90° angle turns or making taps and splices
- Provides long and large openings for pulling large conductors, splicing and taps
- Serve as a pull outlets for conductors that are stiff

STANDARD MATERIAL

- Body - Malleable iron
- Gasket - Neoprene rubber
- Screws - Stainless steel

STANDARD FINISH

- Hot dip galvanized

CERTIFICATIONS

- UL Standard: UL 514A - UL 514D
- Fed. Spec: W-C-586D, A-A-50563
- NEMA: FB 1-2014 - NEMA 3R



MLR3CGHDG

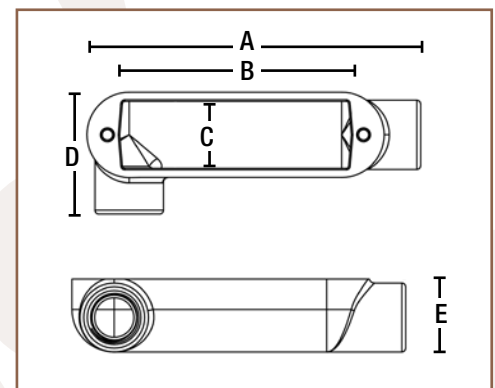

| PART # | SIZE | WIRE SIZE | | INTERNAL VOLUME (IN ³) | MASTER QTY. | WEIGHT/CASE (LBS.) | A | B | C | D | E |
|-----------|--------|-------------|-----------|------------------------------------|-------------|--------------------|--------|-------|-------|-------|-------|
| | | MAX. NUMBER | MAX. SIZE | | | | | | | | |
| MLR3CGHDG | 1" | 3 | 4 AWG | 19 | 1 | 4 | 8.62" | 5.98" | 1.71" | 3.12" | 1.87" |
| MLR4CGHDG | 1-1/4" | 3 | 2 AWG | 25 | 1 | 6 | 8.62" | 5.98" | 1.71" | 3.12" | 2.31" |
| MLR5CGHDG | 1-1/2" | 3 | 1/0 AWG | 57 | 1 | 10 | 12.72" | 10" | 2.26" | 4.08" | 2.58" |
| MLR6CGHDG | 2" | 3 | 4/0 AWG | 75 | 1 | 14 | 12.72" | 10" | 2.26" | 4.08" | 3.17" |

Rev. 0, 03/23

**BUILT FOR DURABILITY.
BUILT FOR RELIABILITY.
BUILT FOR WORK.™**

1-855-798-6657 | SOUTHWIRE.COM

©2023 Southwire Company, LLC. All rights reserved.
*Registered Trademark & ™Trademark of Southwire Company, LLC.