

SERIES 2600 LIFT ASSEMBLY

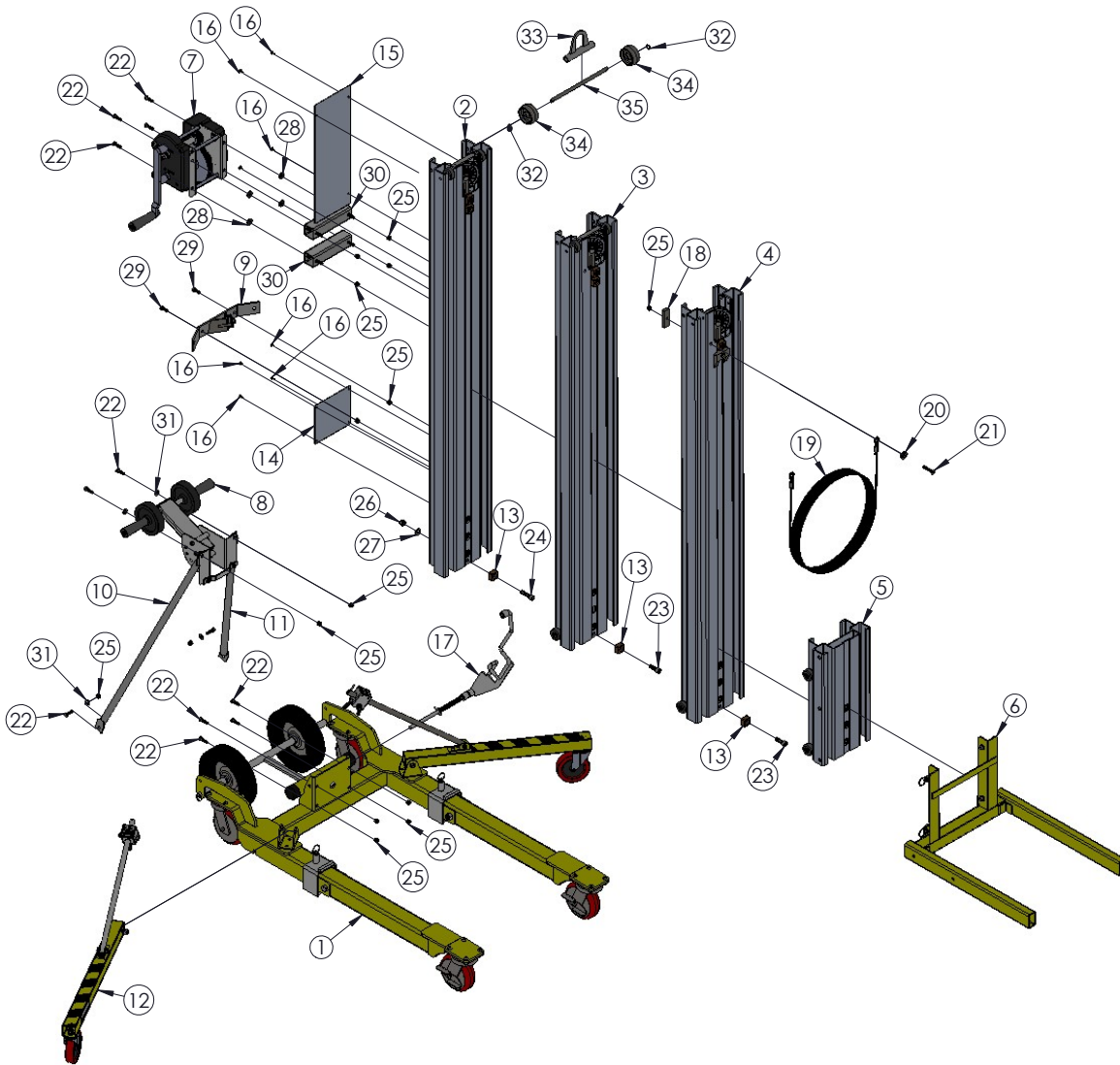

ITEM NO.	PART NUMBER	DESCRIPTION	QTY.
1	783070	BASE ASSEMBLY, 2600 SERIES LIFT	1
2	783160	BOTTOM MAST ASSEMBLY, 2600 SERIES LIFT	1
3	783161	CENTER MAST ASSEMBLY, 2600 SERIES LIFT	1
4	783162	TOP MAST ASSEMBLY, 2600 SERIES LIFT	1
5	783533	CARRIAGE ASSEMBLY	1
6	783165	FORK ASSEMBLY, 2600 SERIES LIFT	1
7	785379	WINCH ASSEMBLY, 2 SPEED 2600 LIFT	1
8	786575	HANDLE ASSEMBLY, CB LIFT	1
9	783582	SPREADER PLATE ASSEMBLY	1
10	780820	BRACE MAST RIGHT	1
11	780819	BRACE MAST LEFT	1
12	783935	OUTRIGGER ASSEMBLY 2000/2100	1
13	783575	STOP BLOCK	3
14	783916	MAST COVER ALUM BTM 2000/2100/2600	1
15	783918	MAST COVER ALUM TOP 2000/2100/2600	1
16	776055	SCREW, SM #8 X 3/4 SELF TAPPING	8
17	783040	MAST HOLD DOWN BAR TYPE 2100	1
18	783551	LOCK BLOCK	1
19	783886	LOAD LINE ASSEMBLY 2010/2610	1
19	783834	LOAD LINE ASSEMBLY 2015/2615	1
20	782910	ROPE RET. WASHER	1
21	771248	SCREW, FHSC 3/8-16 X 2"LN	1
22	771060	SCREW, HHC 3/8-16X1.25"LN	16
23	771257	SCREW, SHC 1/2 - 13 X 1 - 1/2	2
24	771252	SCREW, SHC 1/2-13X2"LN	1
25	772355	NUT, INSERT LOCK 3/8-16	19
26	772358	NUT, INSERT JAM 1/2 -13	1
27	773094	WASHER, FLAT 1/2 SAE	1
28	773005	WASHER FLAT 3/8 RUBBER SEALING	4
29	771107	SCREW, HHC 3/8-16 X 1	2
30	783552	STANDOFF-2112	2
31	773040	WASHER, FLAT 3/8	4
32	774053	PIN, COTTER CIRCLE 3/4"	2
33	786585	LIFTING HOOK WELDMENT	1
34	779012	WHEEL, POLYOLEFIN 3"	2
35	783620	SHAFT, ROLLER	1

UPPER AND LOWER MAST ASSEMBLY

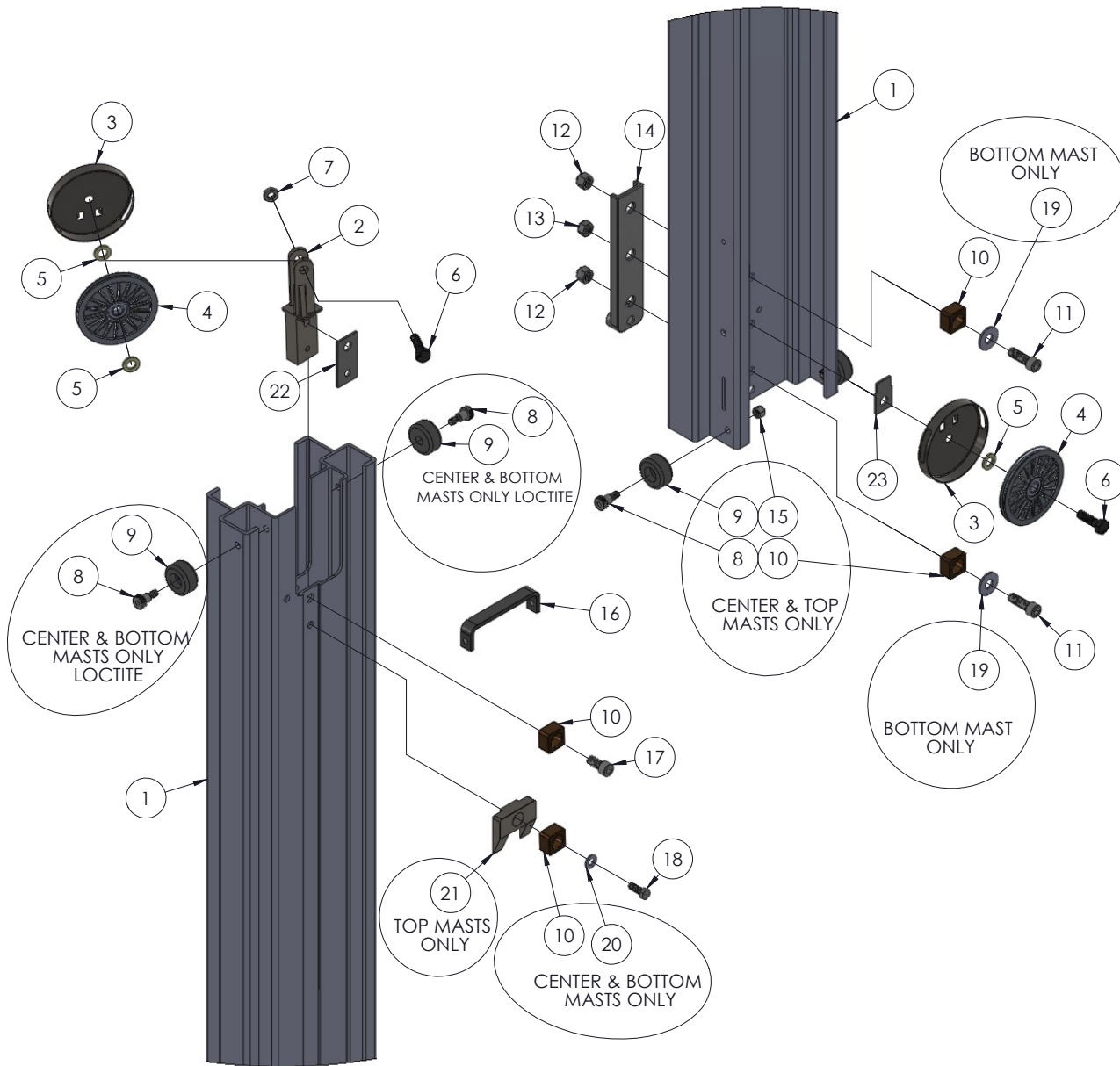

ITEM NO.	PART NUMBER	DESCRIPTION	QTY.
1	783245	BOTTOM MAST MACHINED, 2600 SERIES LIFT	1
2	783489	UPPER PULLEY BRACKET, 2600 SERIES	1
3	783536	PULLEY GUARD	2
4	783921	PULLEY ASSEMBLY	2
5	773108	WASHER, FLAT 7/16" GRADE 8	3
6	771166	M12-1.75 x 40MM HI-STRENGTH 10.9 GRADE	2
7	772505	NUT, INSERT JAM M12	1
8	771350	SCREW, SHOULDER 1/2 X 1/2 (TOP QTY 2)	2
8	771350	SCREW, SHOULDER 1/2 X 1/2 (CENTER QTY 4)	4
8	771350	SCREW, SHOULDER 1/2 X 1/2 (BOTTOM QTY 2)	2
9	783540	MAST ROLLER (TOP QTY 2)	2
9	783540	MAST ROLLER (CENTER QTY 4)	4
9	783540	MAST ROLLER (BOTTOM QTY 2)	2
10	783575	STOP BLOCK (TOP 2)	2
10	783575	STOP BLOCK (CENTER 4)	4
10	783575	STOP BLOCK (BOTTOM 2)	2
11	771257	SCREW, SHC 1/2 - 13 X 1 - 1/2	2
12	772357	NUT, INSERT LOCK 1/2 - 13	2
13	772800	NUT, INSERT LOCK 12MM	1
14	783478	BACK PLATE WELDMENT	1
15	772350	NUT, INSERT JAM 3/8 - 16 (TOP QTY 2)	2
15	772350	NUT, INSERT JAM 3/8 - 16 (CENTER QTY 2)	2
16	783248	2600 REINFORCEMENT BRACKET (CENTER QTY 1)	1
16	783248	2600 TOP REINFORCEMENT BRACKET (BOTTOM QTY 1)	1
17	771258	SCREW, SHC 1/2-13 X 1	1
18	771107	SCREW, HHC 3/8-16 X 1	1
19	773060	WASHER, FLAT 1/2 USS	2
20	773022	WASHER, FLAT 3/8 SAE HARDENED (CENTER QTY 1)	1
20	773022	WASHER, FLAT 3/8 SAE HARDENED (BOTTOM QTY 1)	1
21	783694	STOP BLOCK WEDGE	1
22	783484	PLATE, TOP PULLEY MOUNT 2600	1
23	783069	SHIM, 2600 PULLEY GUARD	1
24	779070	LOWER PULLEY KIT (NOT PICTURED)	1
25	783924	UPPER PULLEY KIT (NOT PICTURED)	1

LOWER PULLEY KIT ASSEMBLY

779070 LOWER PULLEY KIT

NOTE: KIT INCLUDES PARTS 1,2,3,4,5.
MASTS AND OTHER HARDWARE FOR ASSEMBLY REFERENCE ONLY.

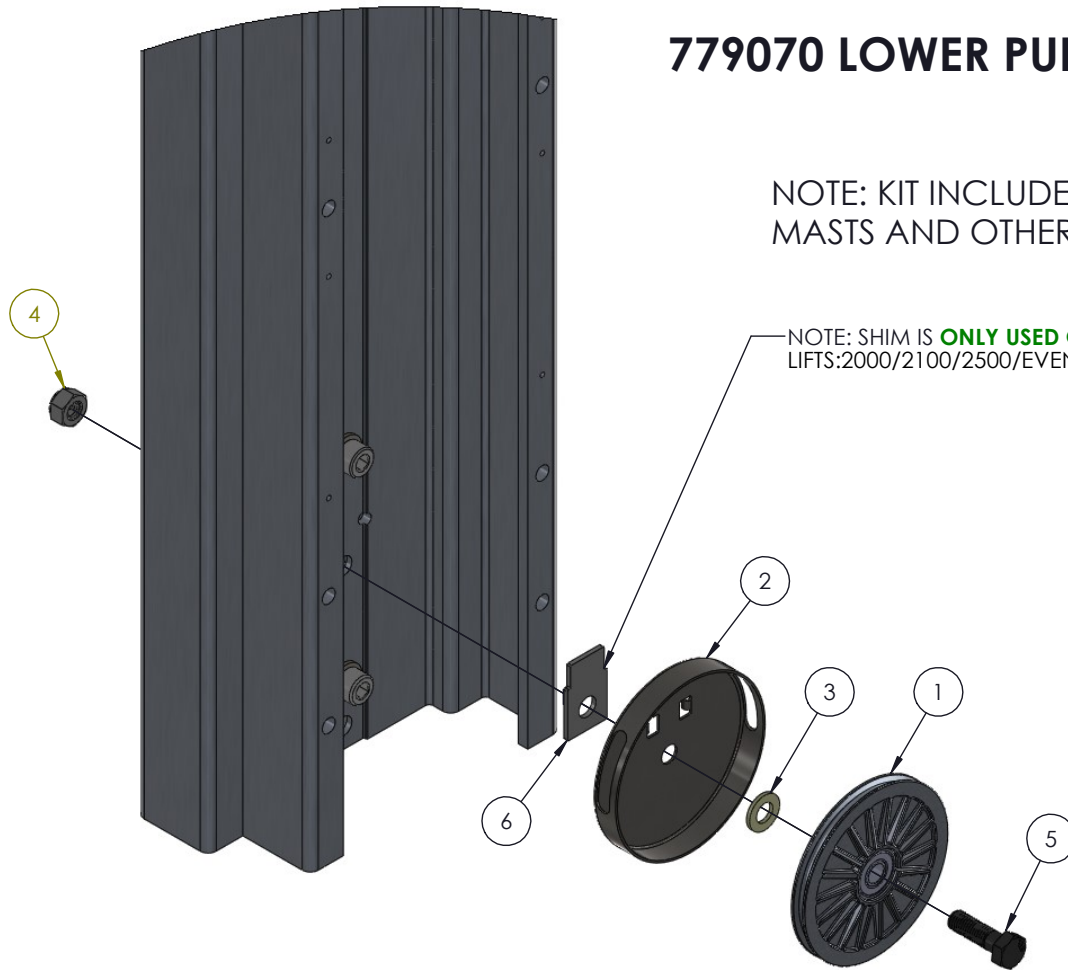

ITEM NO.	PART NUMBER	DESCRIPTION	QTY.
1	783921	PULLEY ASSEMBLY	1
2	783536	PULLEY GUARD	1
3	773108	WASHER, FLAT 7/16" GRADE 8	1
4	772505	NUT, INSERT JAM M12	1
5	771166	High-Strength Class 10.9 Steel Hex Head Screw	1
6	783069	SHIM, 2600 PULLEY GUARD	1

UPPER PULLEY KIT ASSEMBLY

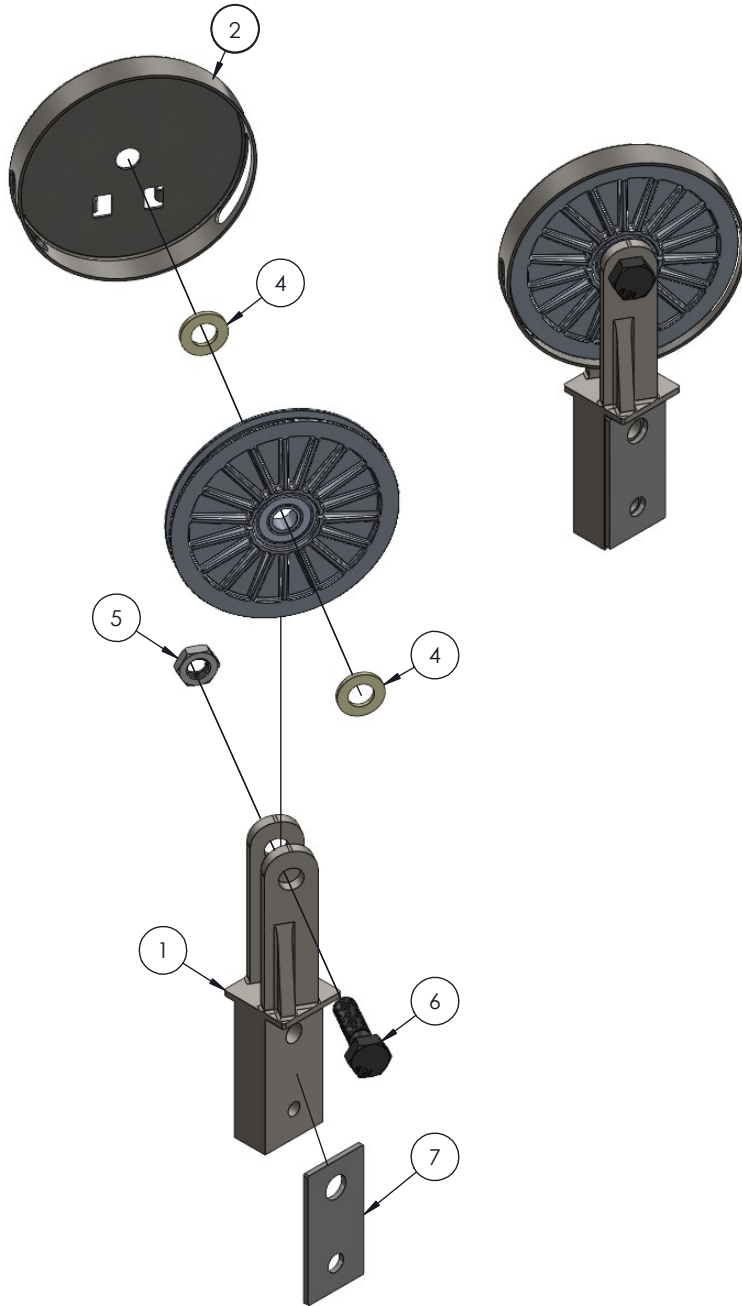

783924 UPPER PULLEY KIT

ITEM NO.	PART NUMBER	DESCRIPTION	QTY.
1	783489	UPPER PULLEY BRACKET, 2600 SERIES	1
2	783536	PULLEY GUARD	1
3	783921	PULLEY ASSEMBLY	1
4	773108	WASHER, FLAT 7/16" GRADE 8	2
5	772505	NUT, INSERT JAM M12	1
6	771166	High-Strength Class 10.9 Steel Hex Head Screw	1
7	783484	PLATE, TOP PULLEY MOUNT 2600	1

CARRIAGE ASSEMBLY (783533)

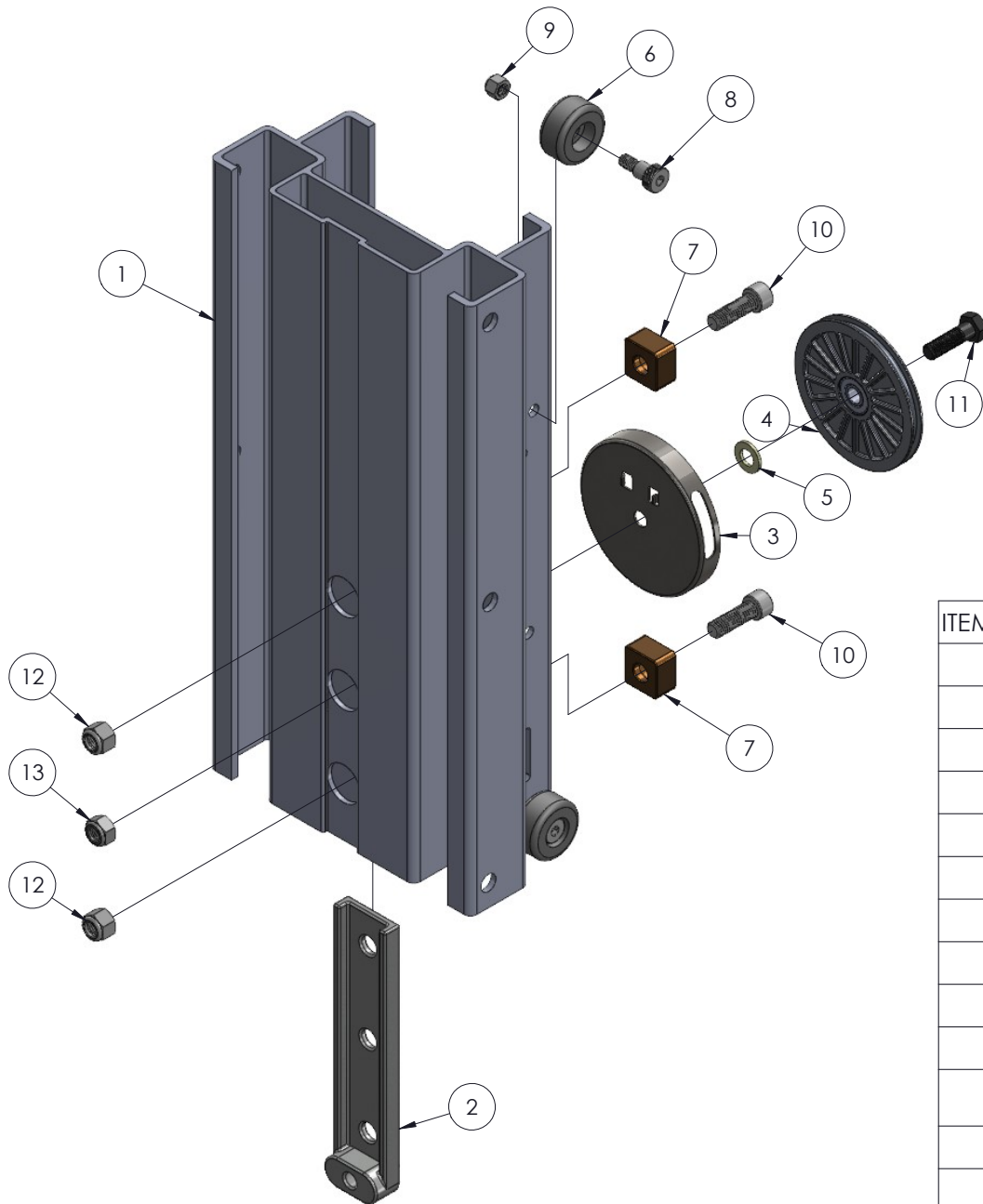

ITEM NO.	PART NUMBER	DESCRIPTION	QTY.
1	783534	CARRIAGE	1
2	783478	BACK PLATE WELDMENT	1
3	783536	PULLEY GUARD	1
4	783921	PULLEY ASSEMBLY	1
5	773108	WASHER, FLAT 7/16" GRADE 8	1
6	783540	MAST ROLLER	4
7	783575	STOP BLOCK	2
8	771350	SCREW, SHOULDER 1/2 X 1/2	4
9	772350	NUT, INSERT JAM 3/8 - 16	4
10	771257	SCREW, SHC 1/2 - 13 X 1 - 1/2	2
11	771166	M12-1.75 x 40MM HI-STRENGTH 10.9 GRADE	1
12	772357	NUT, INSERT LOCK 1/2 - 13	2
13	772800	NUT, INSERT LOCK 12MM	1

MAST BRAKE ASSEMBLY

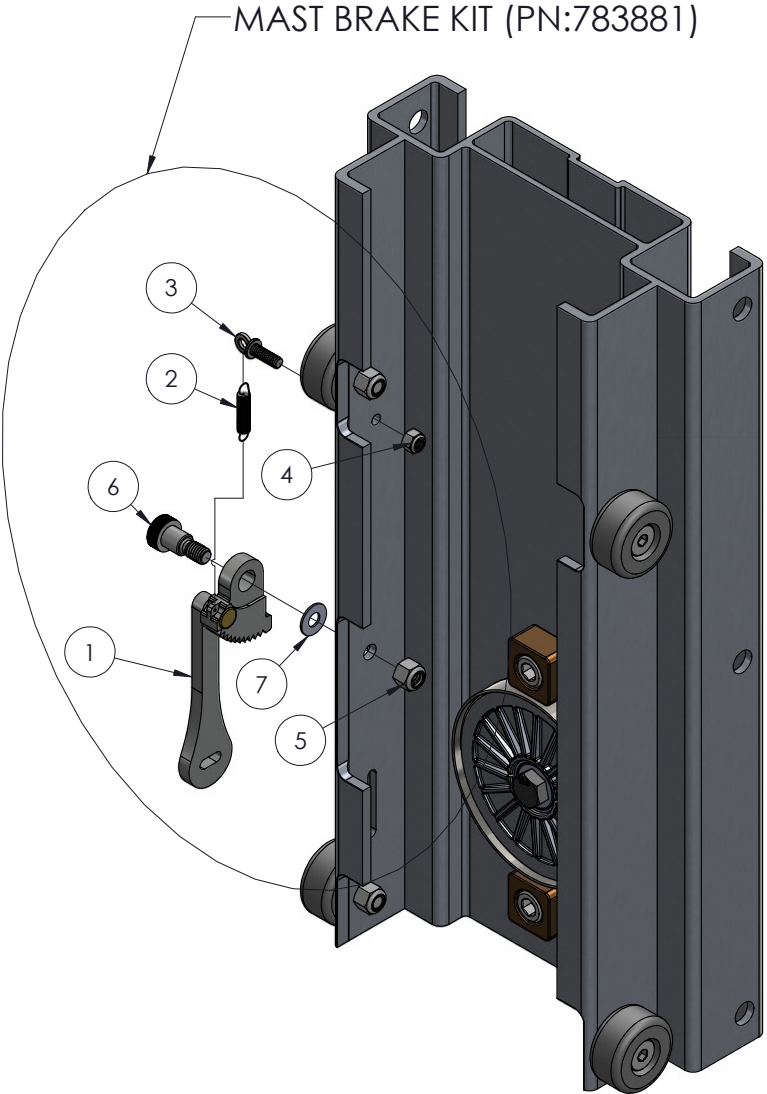

ITEM NO.	PART NUMBER	DESCRIPTION	QTY.
1	783529	MAST BRAKE ASSEMBLY	1
2	783530	BRAKE SPRING	1
3	779900	SCREW, ADJUSTING (OHIO ES2112) EYE BOLT	1
4	772076	NUT, INSERT LOCK 1/4-20	1
5	772350	NUT, INSERT JAM 3/8 - 16	1
6	771350	SCREW, SHOULDER 1/2 X 1/2	1
7	773042	WASHER, FLAT 5/16	1

MAST HOLD DOWN ASSEMBLY (783040)

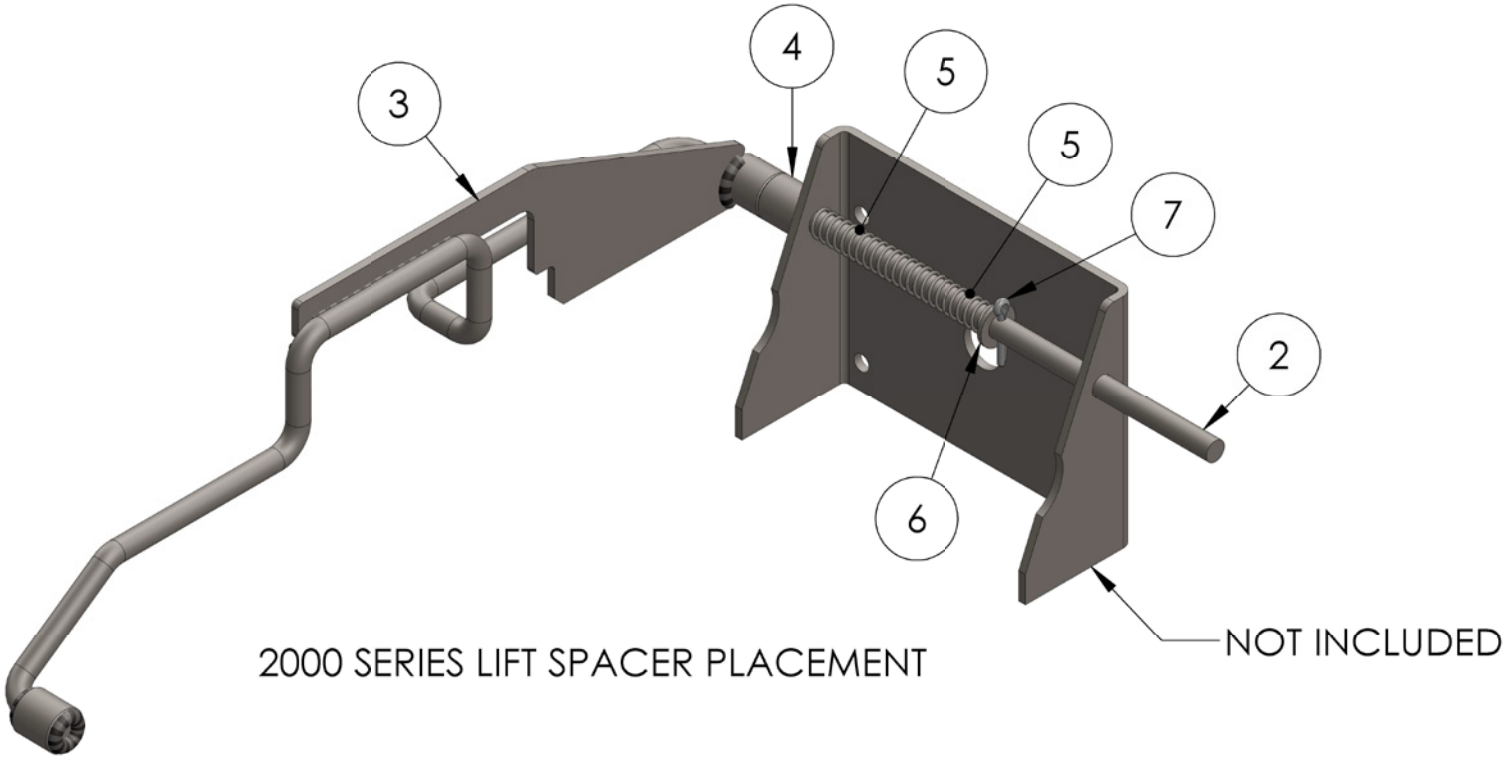

ITEM NO.	PART NUMBER	DESCRIPTION	QTY.
2	783042	MAST HOLD DOWN DEVICE	1
3	783046	MAST HOLD DOWN REINFORCEMENT BRACKET	1
4	783044	MAST HOLD DOWN SPACER	3
5	776216	SPRING, CENTURY #71912S	2
6	773096	WASHER, FLAT M12	1
7	774051	PIN, COTTER 0.125 X 0.75"	1

BASE ASSEMBLY (783070)

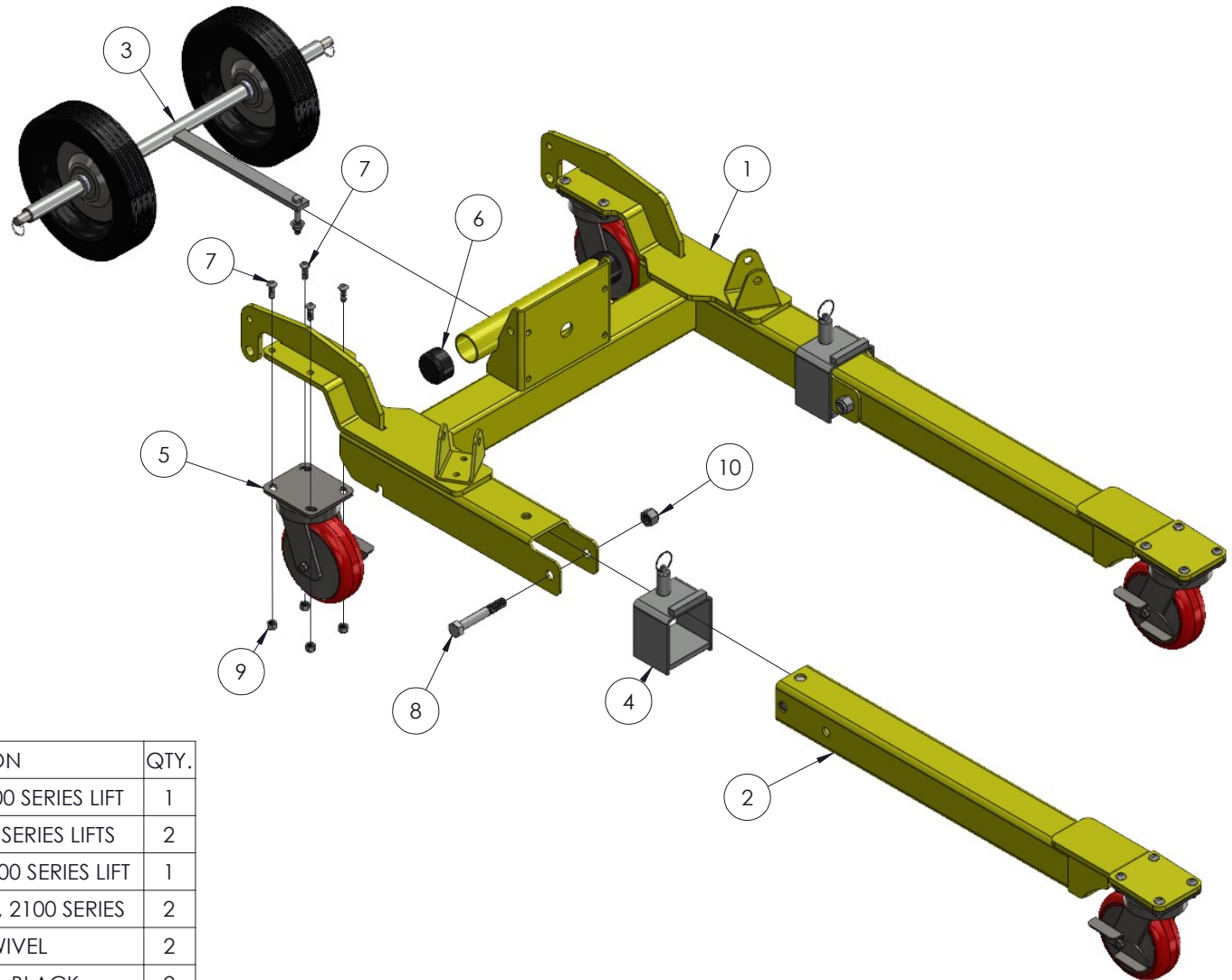

ITEM NO.	PART NUMBER	DESCRIPTION	QTY.
1	783072	BASE WELDMENT, 2600 SERIES LIFT	1
2	783083	LEG ASSEMBLY 2600 SERIES LIFTS	2
3	783094	10 INCH WHEEL KIT 2600 SERIES LIFT	1
4	783746	LEG LOCK ASSEMBLY, 2100 SERIES	2
5	779058	CASTER, 6" SWIVEL	2
6	779905	CAP, 2" OD TUBE, BLACK	2
7	771266	SCREW, BHC 3/8-16 X 1	8
8	771146	SCREW, HHC 5/8-11X4"LN	2
9	772350	NUT, INSERT JAM 3/8 - 16	8
10	772503	NUT, INSERT JAM 5/8-11	2

LEG ASSEMBLY (783083)

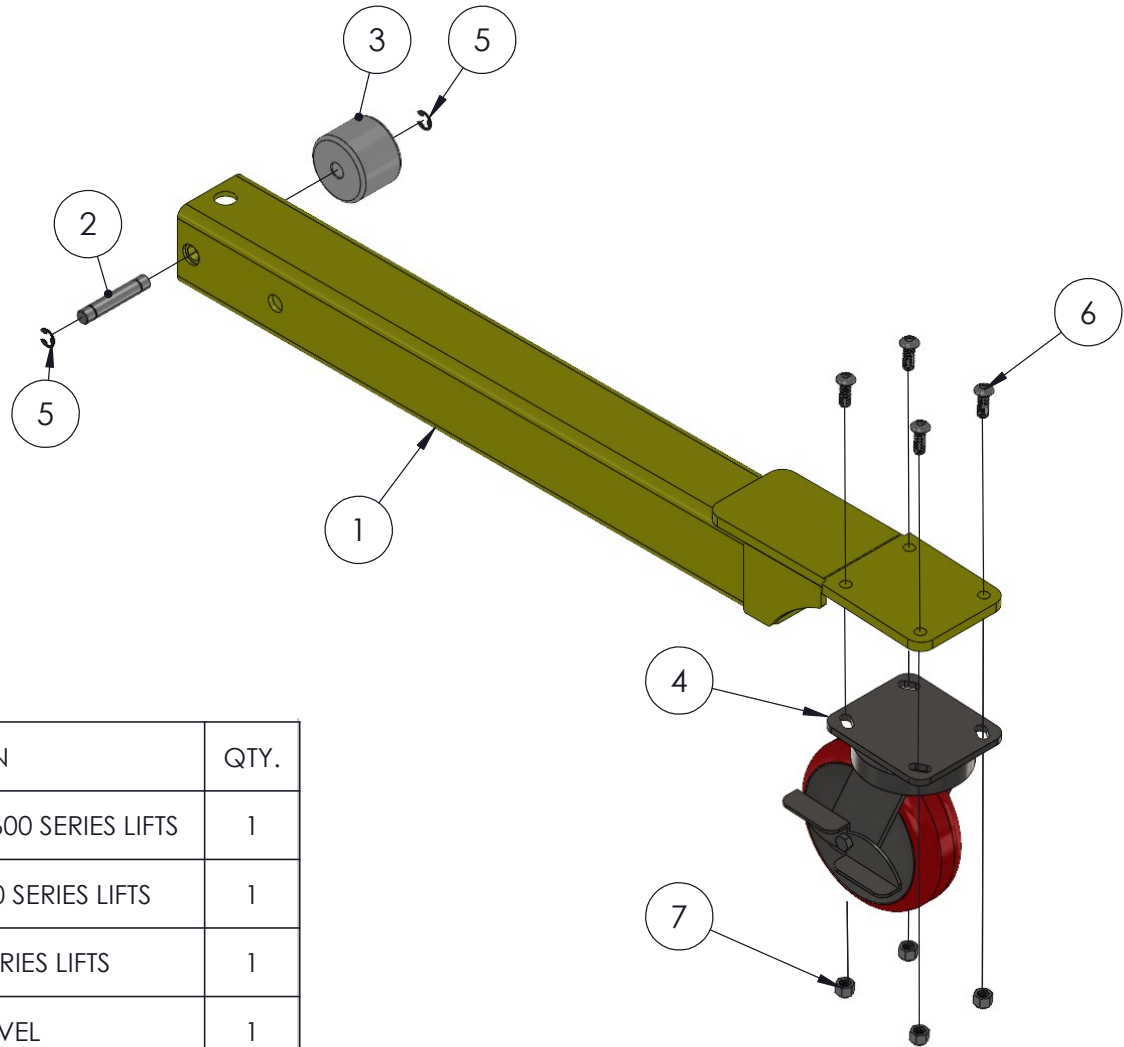

ITEM NO.	PART NUMBER	DESCRIPTION	QTY.
1	783085	FRONT LEG WELDMENT, 2600 SERIES LIFTS	1
2	783090	SHAFT, LEG ROLLER 2600 SERIES LIFTS	1
3	783091	ROLLER, LEG 2600 SERIES LIFTS	1
4	779058	CASTER, 6" SWIVEL	1
5	776079	RETAINING RING #5133-50	2
6	771266	SCREW, BHC 3/8-16 X 1	4
7	772350	NUT, INSERT JAM 3/8 - 16	4

LEG LOCK ASSEMBLY (783746)

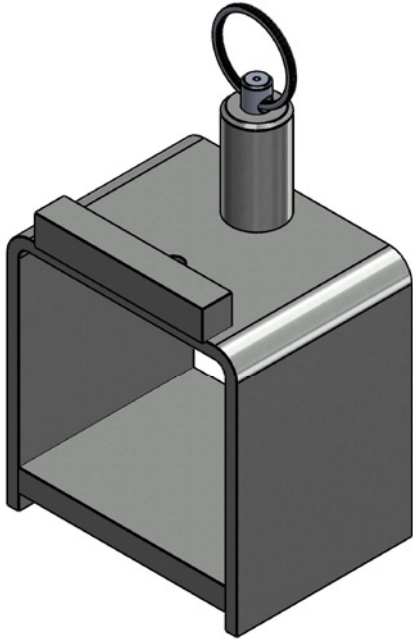
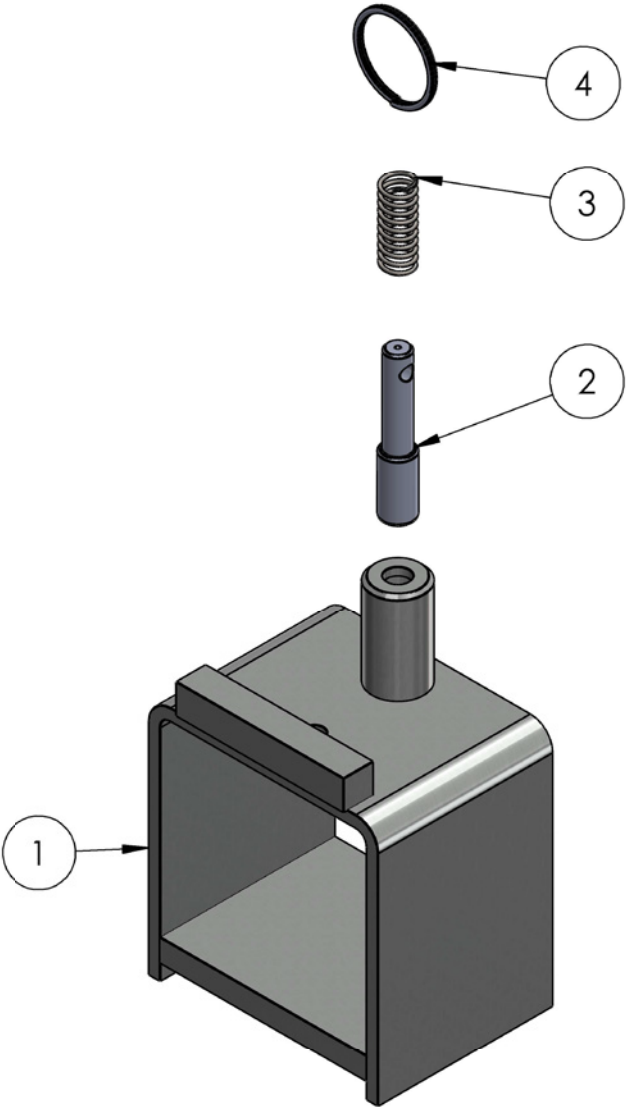

ITEM NO.	PART NUMBER	DESCRIPTION	QTY.
1	783740	LEG LOCK WELDMENT, 2100 SERIES	1
2	782510	PLUNGER	1
3	776212	SPRING, #DWC - 042 - G - 9	1
4	775110	SPLIT RING 1-1/4" NICKEL PLATED	1

OUTRIGGER ASSEMBLY (783935)

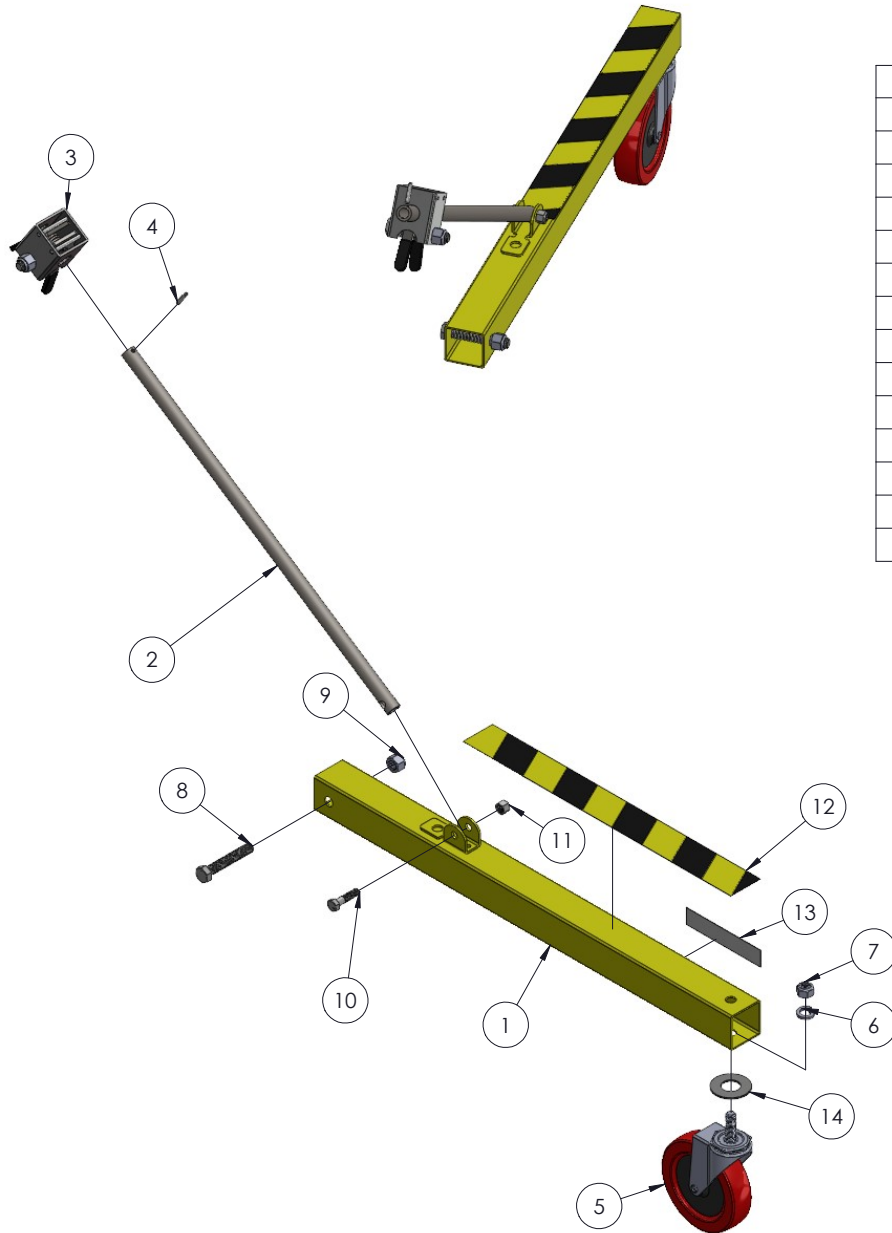

ITEM NO.	PART NUMBER	DESCRIPTION	QTY.
1	783528	LEG WELDMENT, OUTRIGGER	2
2	783938	OUTRIGGER SUPPORT TUBE, 2500	2
3	783940	OUTRIGGER LOCK ASSEMBLY	2
4	774080	PIN ROLL 3/16 X 1.0" LN	2
5	779002	CASTER, 125 X 32 12MM STEM	2
6	773590	WASHER, LOCK 1/2	2
7	772801	NUT, HEX 12MM ZINC PLATED	2
8	771142	SCREW, HHC 1/2-13 X 3"	2
9	772358	NUT, INSERT JAM 1/2 -13	2
10	771090	SCREW, HHC 3/8-16 X 1.5"	2
11	772350	NUT, INSERT JAM 3/8 - 16	2
12	778352	TAPE, 2" B/Y CAUTION STRIPE	2
13	778348	LABEL, LOWER STABILIZER LEG	2
14	773091	WASHER, FLAT 7/8" USS PLATED	2

OUTRIGGER LOCK ASSEMBLY (783940)

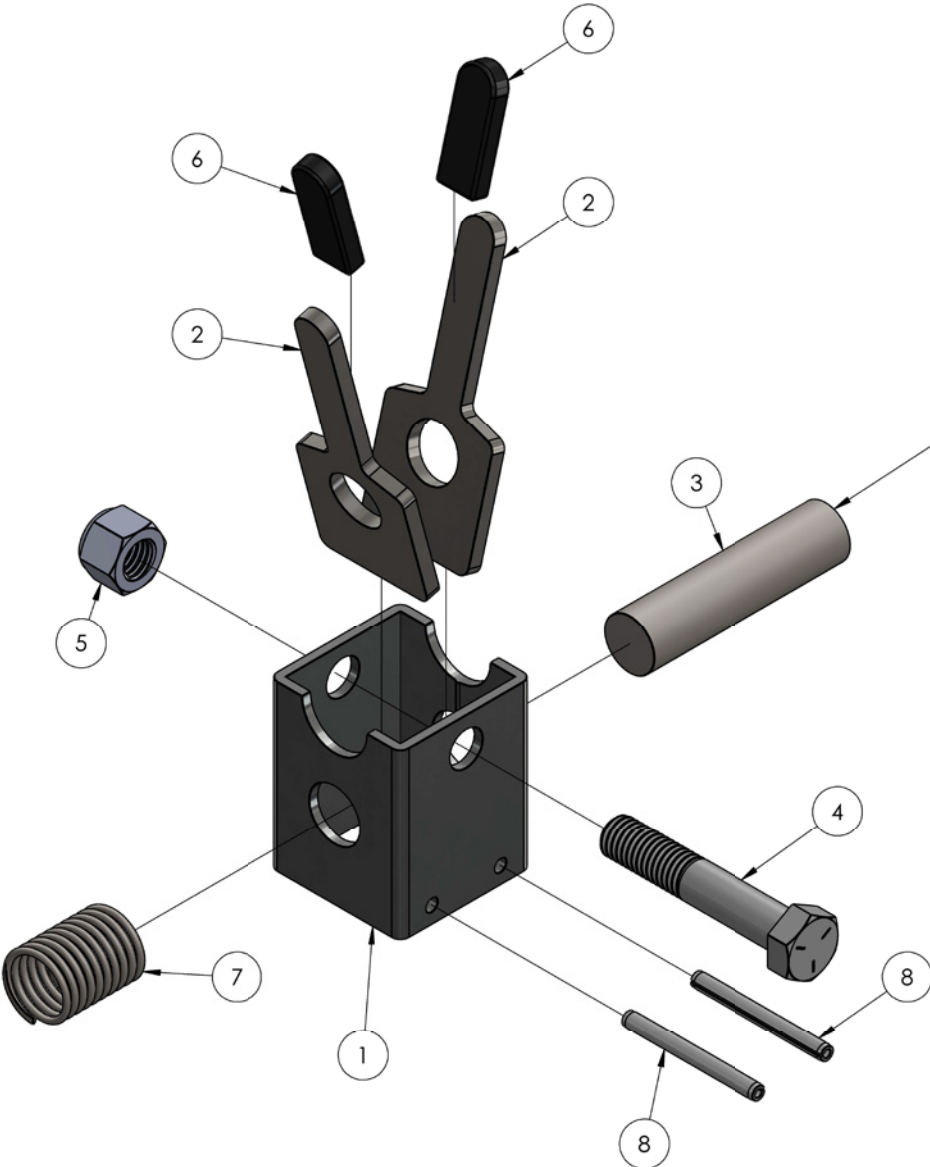

OUTRIGGER SUPPORT TUBE STUB LOCKS ASSEMBLY IS INSTALLED TO SUPPORT THE ASSEMBLY DURING SHIPMENT AND IS TO BE DISCARDED BEFORE INSTALLATION.

ITEM NO.	PART NUMBER	DESCRIPTION	QTY.
1	783941	OUTRIGGER LOCK TUBE	1
2	783942	OUTRIGGER LOCK FINGER	2
3	783944	OUTRIGGER SUPPORT TUBE STUB	1
4	771141	SCREW, HHC 1/2-13X2.75" LN	1
5	772358	NUT, INSERT JAM 1/2 -13	1
6	779938	CAP, RECT RD END 3/16X0.5X2.0"	2
7	776221	CENTURY SPRING #2952	1
8	774084	PIN, SPRING 3/16X2.0"	2

FORK ASSEMBLY (783165)

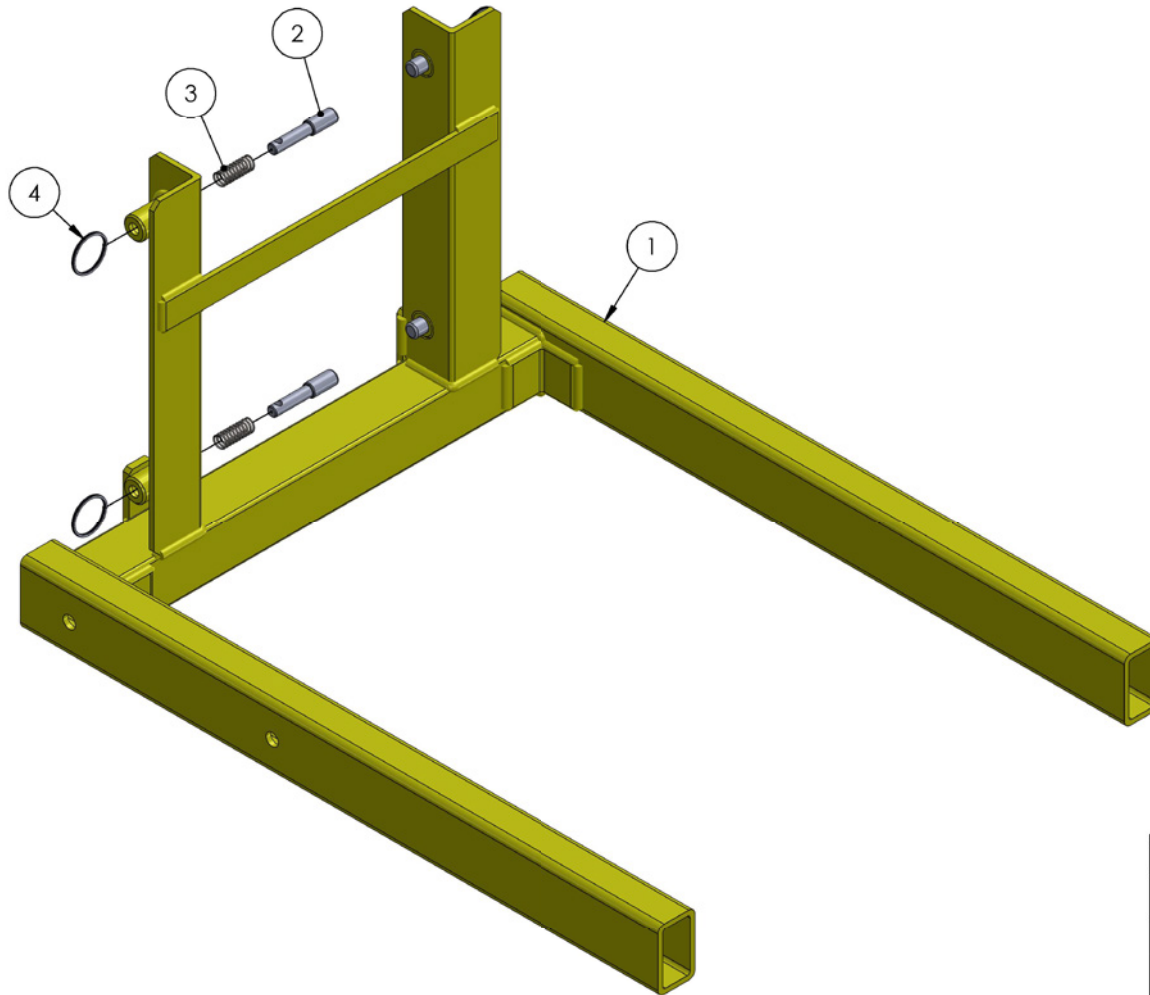

ITEM NO.	PART NUMBER	DESCRIPTION	QTY.
1	783166	FORK WELDMENT, 2600 SERIES LIFTS	1
2	782510	PLUNGER	4
3	776212	SPRING, #DWC - 042 - G - 9	4
4	775110	SPLIT RING 1-1/4" NICKLE PLATED	4

FORK EXTENSION ASSEMBLY (783163)

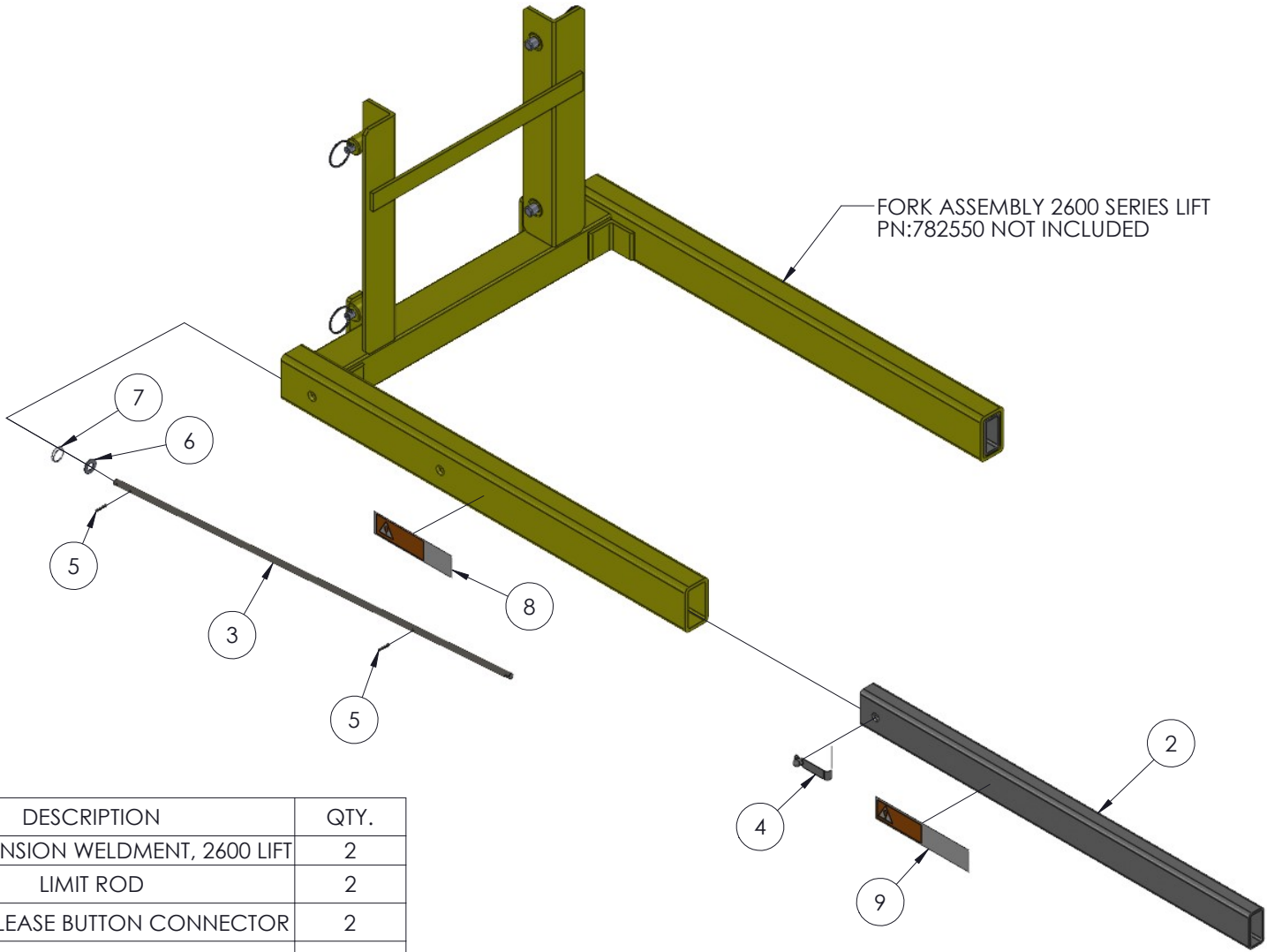

ITEM NO.	PART NUMBER	DESCRIPTION	QTY.
2	783168	FORK EXTENSION WELDMENT, 2600 LIFT	2
3	783589	LIMIT ROD	2
4	774010	QUICK RELEASE BUTTON CONNECTOR	2
5	774092	PIN, ROLL 1/8 X 0.625"	4
6	773042	WASHER, FLAT 5/16	2
7	774053	COTTER, CIRCLE Z/P 0.048 X 0.75"	2
8	778340	LABEL, FORK EXTENSION WARNING	2
9	778349	LABEL , WARNING MAX LOAD	2

10 IN. WHEEL KIT ASSEMBLY (783094)

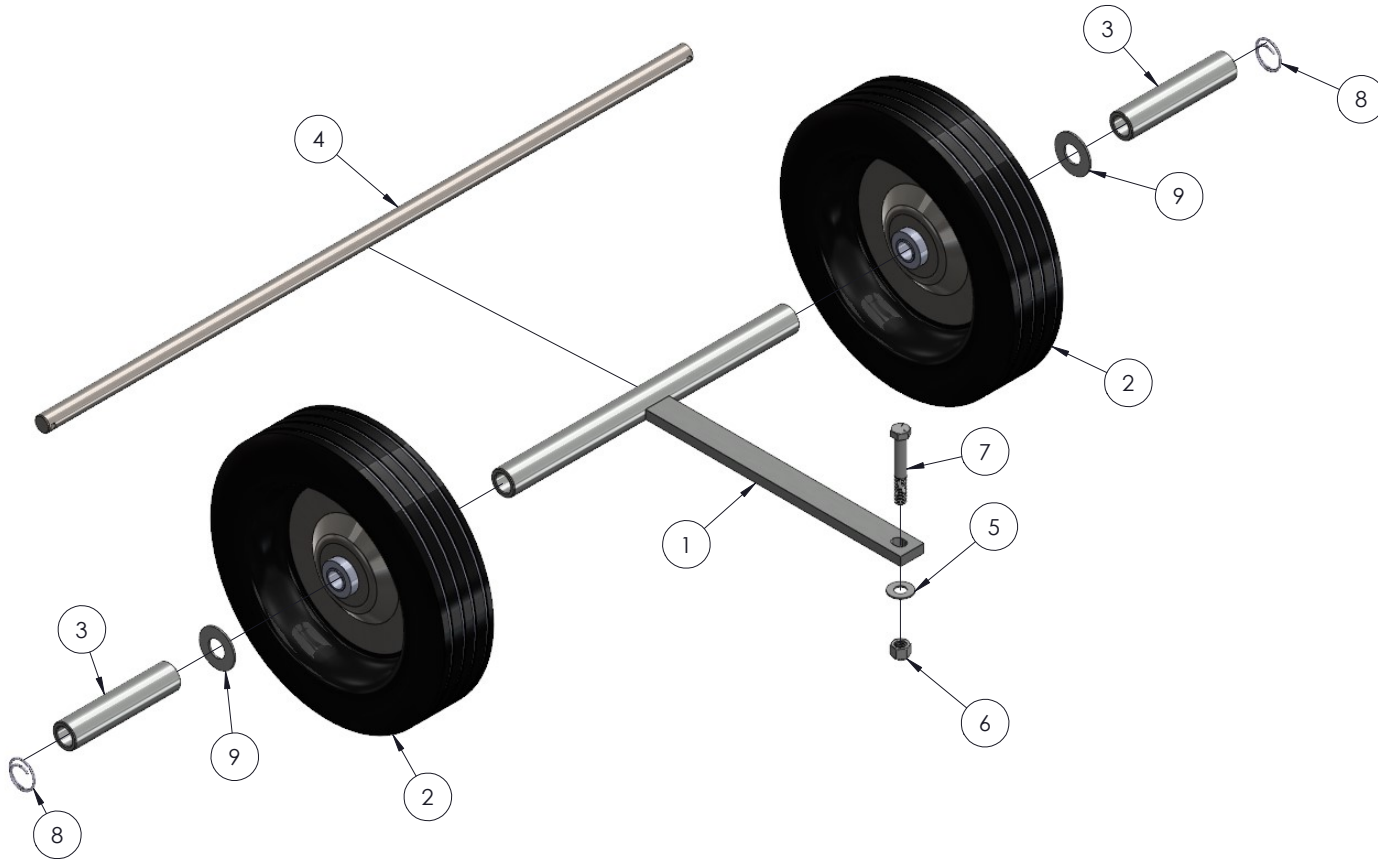

ITEM NO.	PART NUMBER	DESCRIPTION	QTY.
1	783095	AXLE SUPPORT WELDMENT, 10" WHEEL KIT 2600 LIFT	1
2	779011	WHEEL, 10" RUBBER TIRE	2
3	783038	OUTSIDE AXLE SPACER, 2600 SERIES LIFT	2
4	782544	AXLE, MODEL 209	1
5	773040	WASHER, FLAT 3/8	1
6	772355	NUT, INSERT LOCK 3/8-16	1
7	771110	SCREW, HHC 3/8-16 X 2.5"LN	1
8	774054	COTTER, CIRCLE Z/P 0.072 X 1.125"	2
9	773051	WASHER, FLAT 5/8 USS	2

SPREADER PLATE ASSEMBLY (783582)

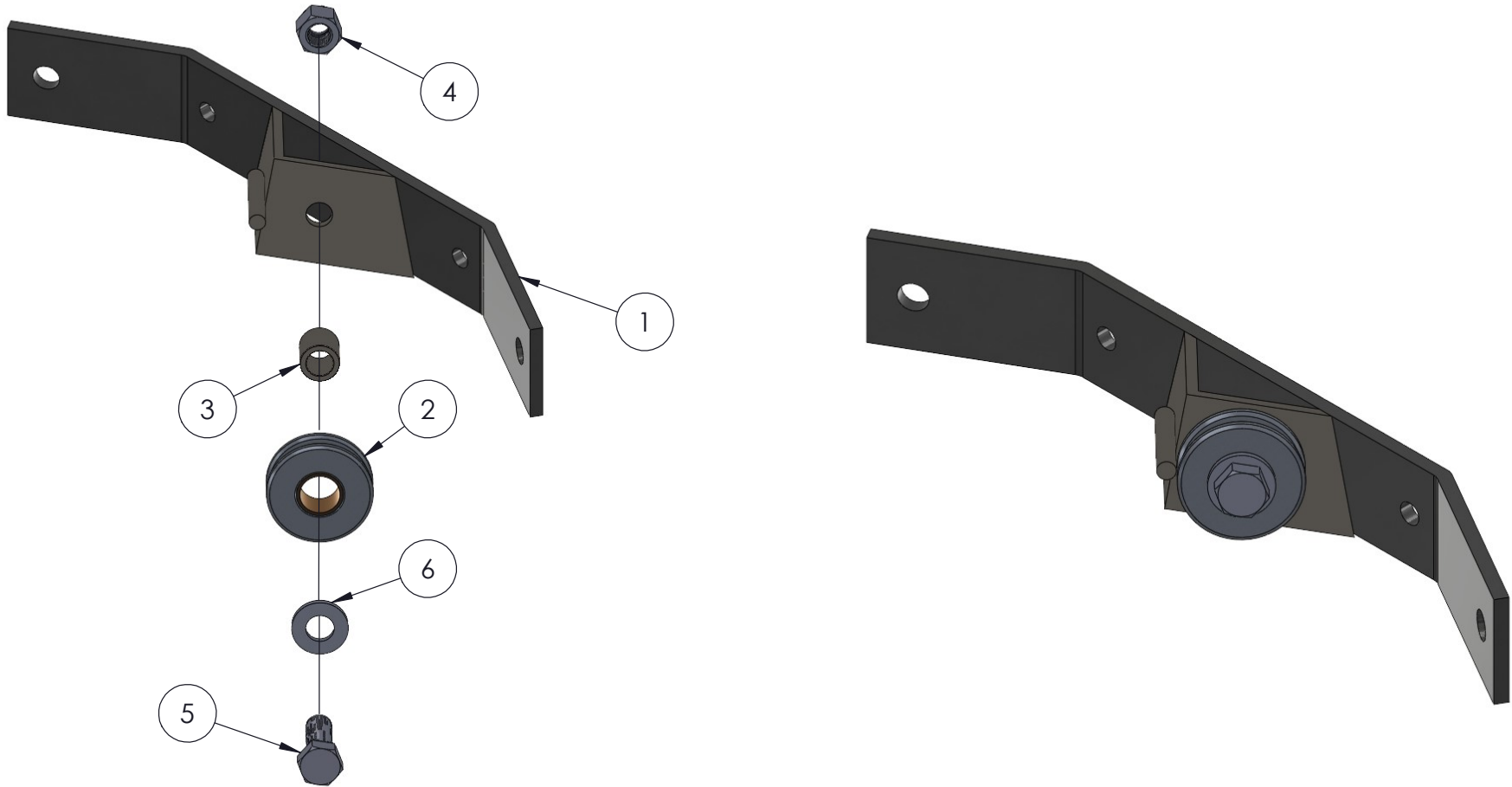

ITEM NO.	PART NUMBER	DESCRIPTION	QTY.
1	783581	SPREADER PLATE WELDMENT	1
2	780025	SHEAVE, RAB-222 (2") Z-22	1
3	782960	ROLLER SHAFT, CARR.715/720	1
4	772358	NUT, INSERT JAM 1/2 -13	1
5	771120	SCREW, HHC 1/2-13 x 1.5" LN	1
6	773094	WASHER, FLAT 1/2 SAE	1

2 SPEED WINCH ASSEMBLY (785379)

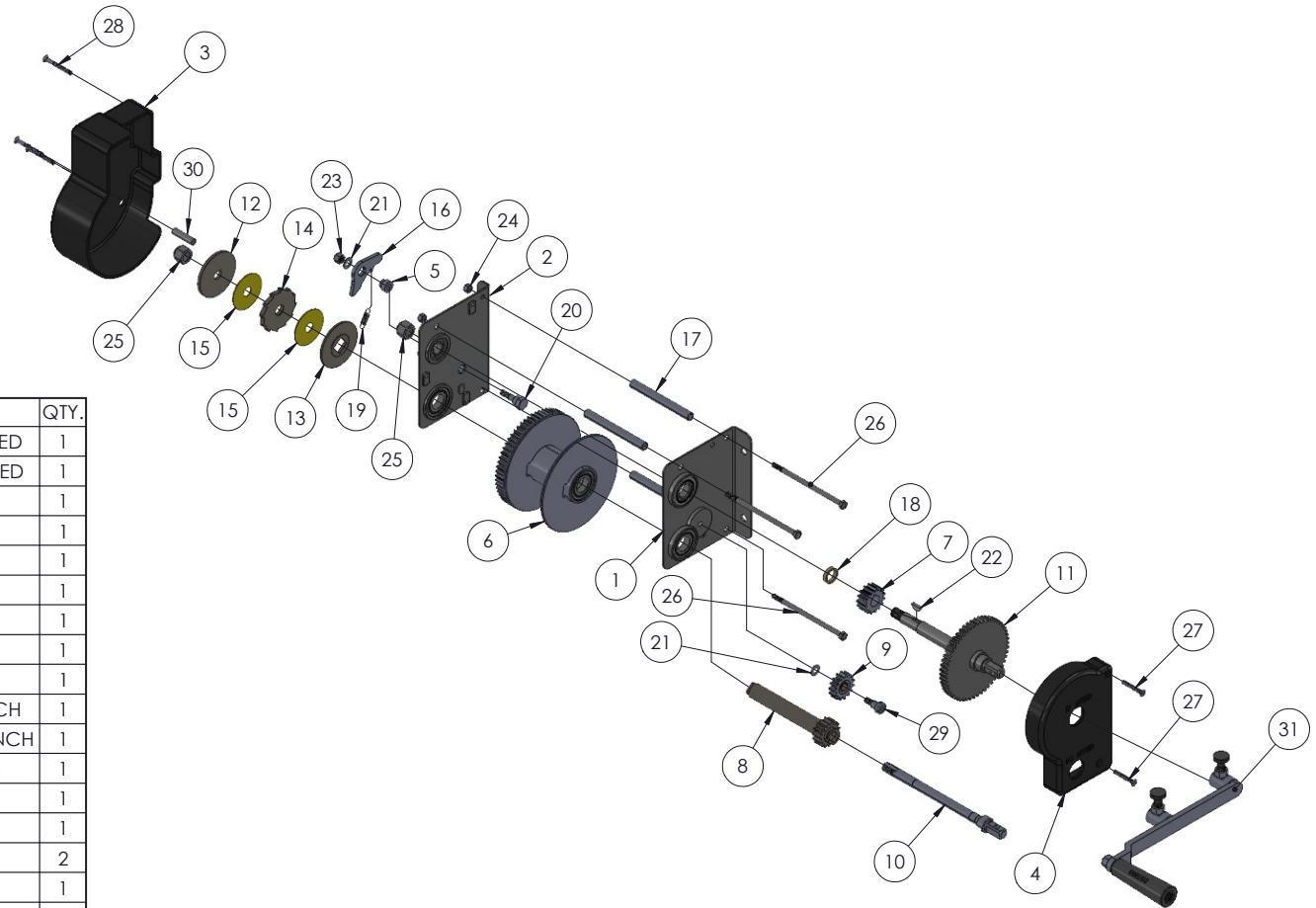

ITEM NO.	PART NUMBER	DESCRIPTION	QTY.
1	785381	SIDE PLATE ASSEMBLY -LH, WINCH 2-SPEED	1
2	785382	SIDE PLATE ASSEMBLY -RH, WINCH 2-SPEED	1
3	785395	WINCH COVER, RH WINCH 2-SPEED	1
4	785396	WINCH COVER, LH WINCH 2-SPEED	1
5	780251	RATCHET DOG SPACER WJ-55	1
6	780202	LOAD DRUM FINAL WLDMNT/ ASSY	1
7	780204	LOAD DRUM PINION WJ-5	1
8	784501	SHAFT, LOW SPEED PINION, SQ END	1
9	780207	IDLER GEAR ASSEMBLY	1
10	785393	LOW SPEED DRIVE SHAFT, 2-SPEED WINCH	1
11	785391	HI-SPD DRIVE SHAFT WLDMT, 2-SPEED WINCH	1
12	780212	PLATE, OUTER BRAKE DISC, NL WINCH	1
13	784498	PLATE, INNER BRAKE DISC, NL WINCH	1
14	780214	BRAKE RATCHET WJ-15	1
15	786955	UNIVERSAL BRAKE DISC	2
16	780217	LOAD RATCHET DOG WJ-20	1
17	780221	SPREADER BAR WJ-24	3
18	780225	LOAD DRUM PINION SPACER WJ-28	1
19	783621	RATCHET DOG SPRING	1
20	780612	RATCHET STUD CS-49	1
21	773042	WASHER, FLAT 5/16	2
22	774075	KEY #606 3/16" X 3/4"	1
23	772350	NUT, INSERT JAM 3/8 - 16	1
24	772502	NUT, INSERT JAM 5/16-18	3
25	772375	NUT, INSERT JAM 5/8 -16	2
26	771051	SCREW, HHC 5/16-18 X 6 GRD-2	3
27	771286	SCREW, FHM 1/4-20 X 1-3/4	2
28	771290	SCREW, FHSC 1/4-20 X 2.25"LN	3
29	780496	SHOULDER SCREW MODIFIED CS-51	1
30	785376	SPACER, 2 SPEED WINCH COVER	1
31	785398	WINCH HANDLE ASSEMBLY, 2 SPEED CB LIFT	1

HANDLE ASSEMBLY (786575)

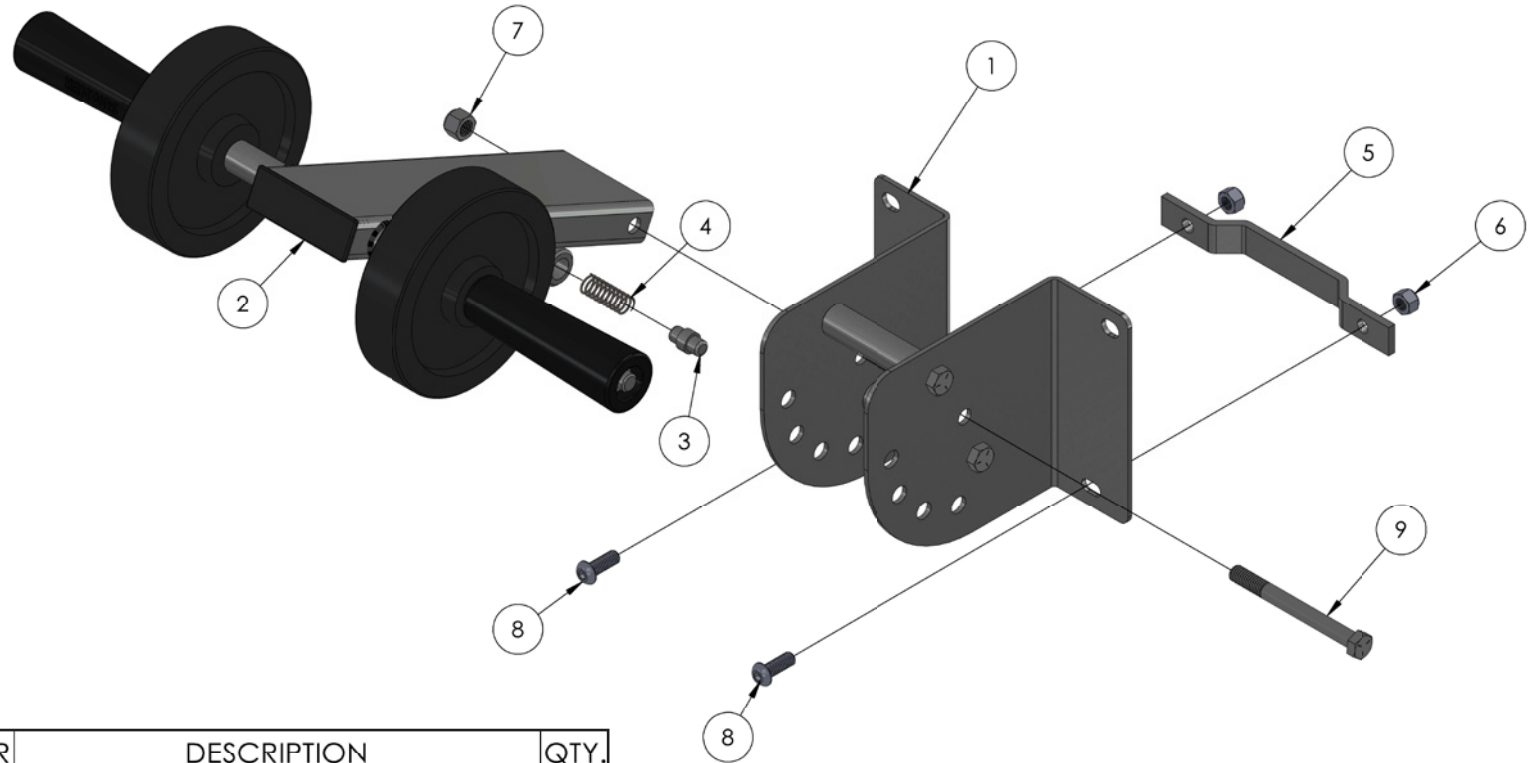

ITEM NO.	PART NUMBER	DESCRIPTION	QTY.
1	786576	HANDLE MOUNTING PLATE ASSEMBLY	1
2	786580	WHEEL HANDLE ASSEMBLY	1
3	783509	PIN DETENT	1
4	776212	SPRING, #DWC - 042 - G - 9	1
5	786696	STRAP FOR HANDLE ASSEMBLY	1
6	772502	NUT, INSERT JAM 5/16-18	2
7	772350	NUT, INSERT JAM 3/8 - 16	1
8	771239	SCREW, BHC 5/16-18 X 7/8	2
9	771098	SCREW, HHC 3/8-16 X 3-3/4	1