



Southwire™

MC CABLE CONNECTOR

FEATURES

- UL listed for use with MC, AC, FMC, RWFMC, MCI, MCI-A and HCF cables
- Tri-combo screw head

APPLICATION

- Dry location use only: Use to connect NM, armored or metal clad cable to box or enclosure
- Use to connect steel or aluminum FMC, AC, MC, HCF cables and aluminum MCC and MCI-A cable to box or enclosure

STANDARD MATERIAL

- Zinc die cast
- Zinc plated steel strap



170TZ

PART #	KO SIZE	SIZE	CABLE TYPE	CABLE SIZE	OPENING MAX.	OPENING MIN.	WIRE BUNDLE DIAMETER MIN.	WIRE BUNDLE DIAMETER MAX.
170TZ	1/2"	3/8"	AC STEEL	14/2 – 8/2	0.65	0.475	0.210	0.450
			AC STEEL HCF	14/2 – 8/2	0.65	0.475	0.220	0.460
			AC ALUMINUM	14/2 – 8/2	0.665	0.464	0.210	0.450
			AC ALUM HCF	14/2 – 8/2	0.665	0.464	0.220	0.460
			MCI STEEL	14/2 – 10/4	0.625	0.455	0.220	0.385
			MCI ALUMINUM	14/2 – 10/4	0.625	0.455	0.220	0.385
			MCI-A	14/2 – 10/4	0.565	0.385	0.220	0.390
			MCI-A HCF	14/2 – 10/4	0.565	0.385	0.240	0.440
			MC-PCS STEEL	12/2 - 12/3	0.610	0.529	0.360	0.380
			MC-PCS ALUMINUM	12/2 - 12/3	0.610	0.529	0.360	0.380
			FLEX CONDUIT	3/8"	0.610	0.560	---	---

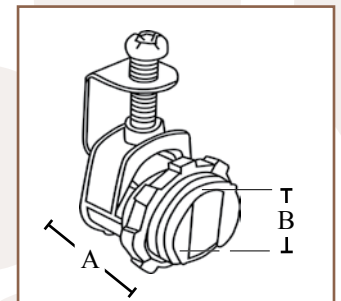

PART #	SIZE	KO	INNER QTY.	MASTER QTY.	WEIGHT/ CASE (LBS.)	A	B (MIN. – MAX.)
170TZ	3/8"	1/2"	50	500	40	.935"	.40" – .61"

Rev. 0, 05/23

**BUILT FOR DURABILITY.
BUILT FOR RELIABILITY.
BUILT FOR WORK.™**

1-855-798-6657 | SOUTHWIRE.COM

©2023 Southwire Company, LLC. All rights reserved.
*Registered Trademark & ™Trademark of Southwire Company, LLC.