



Southwire®

EMT CONNECTORS

COMPRESSION TYPE WITH INSULATED THROAT - STEEL

FEATURES

- Compression type connectors
- Concrete tight
- Assembled with a steel locknut
- Insulated throat

APPLICATION

- Use to join EMT to box or enclosure

STANDARD MATERIAL

- Steel

STANDARD FINISH

- Zinc plated

CERTIFICATIONS

- UL Standard: UL 514B
- Fed. Spec: W-F-406E, W-F-406D
- NEMA: FB1-2014



652Si

PART #	SIZE	INNER QTY.	MASTER QTY.	WEIGHT/ CASE (LBS.)	A	B	C
651Si	1/2"	25	250	30	1.75"	1.25"	.406"
652Si	3/4"	25	250	33	1.813"	1.563"	.406"
653Si	1"	10	100	28	2"	1.813"	.406"
654Si	1-1/4"	---	25	8	2.75"	2.188"	.50"
655Si	1-1/2"	---	20	9	3"	2.438"	.50"
656Si	2"	---	15	12	3.188"	2.938"	.688"
657Si	2-1/2"	---	12	19	3.875"	3.688"	.75"
658Si	3"	---	12	25	4.375"	4.313"	.938"
659Si	3-1/2"	---	6	15	4.50"	4.875"	.938"
660Si	4"	---	6	19	4.75"	5.375"	.938"

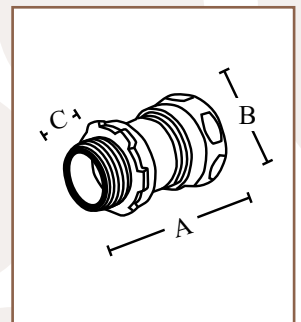

Rev. 0, 05/23

**BUILT FOR DURABILITY.
BUILT FOR RELIABILITY.
BUILT FOR WORK.™**

1-855-798-6657 | SOUTHWIRE.COM

©2023 Southwire Company, LLC. All rights reserved.
*Registered Trademark & ™Trademark of Southwire Company, LLC.