

SERIES 2100 LIFT ASSEMBLY

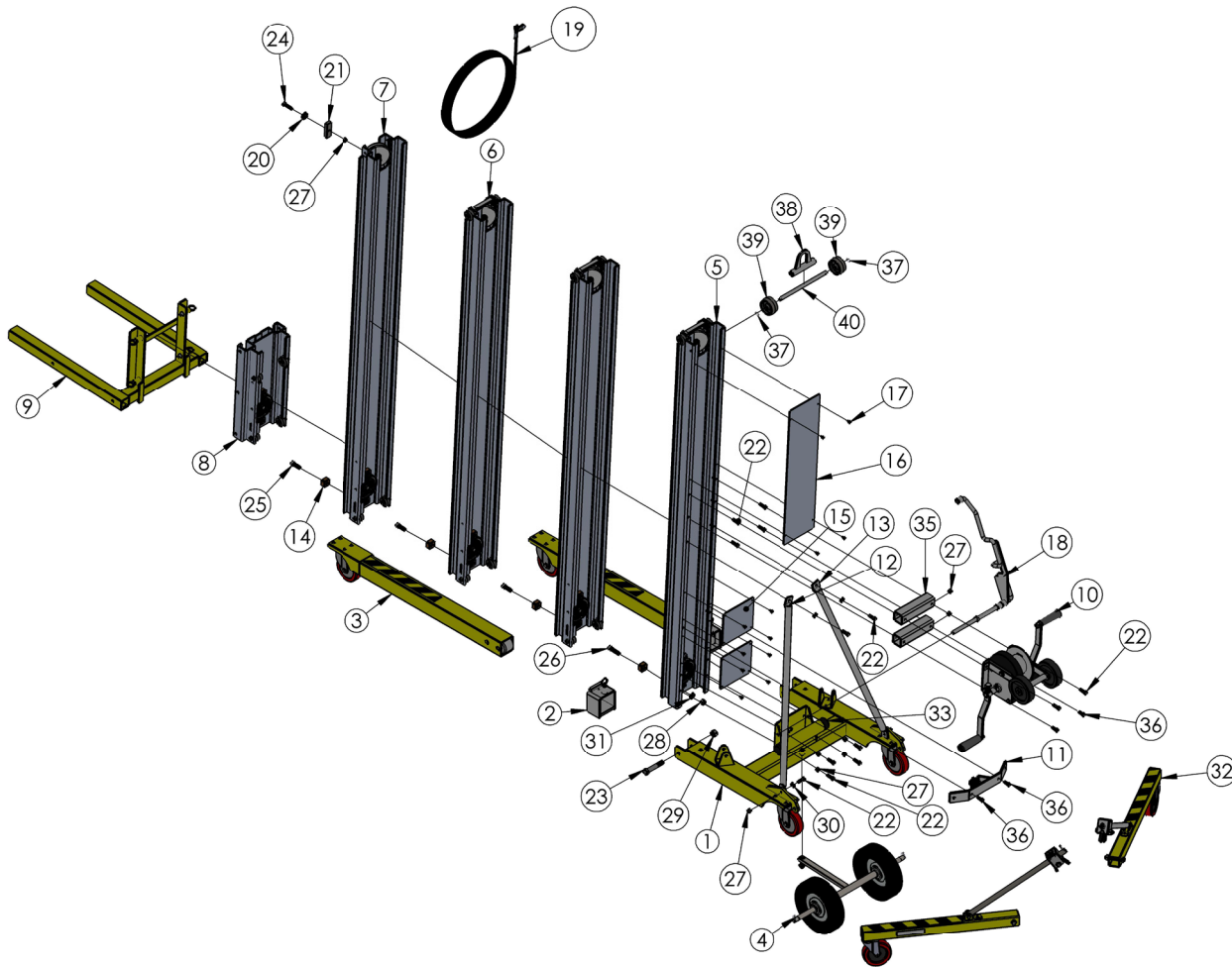

ITEM NO.	PART NUMBER	DESCRIPTION	QTY.
37	774053	PIN, COTTER CIRCLE 3/4"	2
38	786585	LIFTING HOOK WELDMENT	1
39	779012	WHEEL, POLYOLEFIN 3"	2
40	783620	SHAFT, ROLLER	1

ITEM NO.	PART NUMBER	DESCRIPTION	QTY.
1	783750	BASE ASSEMBLY, 2100 LIFT	1
2	783746	LEG LOCK ASSEMBLY, 2100 SERIES	2
3	783730	FRONT LEG ASSEMBLY 10/12/15	2
3	783739	FRONT LEG ASSEMBLY 18/20/24/25	2
4	783736	10" WHEEL KIT, 2100 SERIES	1
5	783660	BOTTOM MAST ASSEMBLY-2100	1
6	783662	CENTER MAST ASSEMBLY	2
7	783683	TOP MAST ASSEMBLY	1
8	783682	CARRIAGE ASSEMBLY	1
9	783653	STANDARD FORK ASSEMBLY	1
10	784490	NL WINCH ASSEMBLY	1
11	783582	SPREADER PLATE ASSEMBLY	1
12	780819	BRACE MAST LEFT	1
13	780820	BRACE MAST RIGHT	1
14	783575	STOP BLOCK	4
15	783916	MAST COVER ALUM BTM 2000/2100/2600	2
16	783919	MAST COVER ALUM TOP 2100	1
17	776055	SCREW, SM #8 X 3/4 SELF TAPPING	12
18	783040	MAST HOLD DOWN BAR TYPE 2100	1
19	783628	LOAD LINE ASSEMBLY, 2012/2112	1
19	783629	LOAD LINE ASSEMBLY, 2018/2118	1
19	783630	LOAD LINE ASSEMBLY, 2024/2124	1
20	782910	ROPE RET. WASHER	1
21	783551	LOCK BLOCK	1
22	771060	SCREW, HHC 3/8-16X1.25"LN	14
23	771146	SCREW, HHC 5/8-11X4"LN	2
24	771248	SCREW, FISC 3/8-1X2"LN	1
25	771257	SCREW, SHC 1/2 - 13 X 1 - 1/2	3
26	771252	SCREW, SHC 1/2-13X2"LN	1
27	772355	NUT, INSERT LOCK 3/8-16	19
28	772358	NUT, INSERT JAM 1/2 -13	1
29	772503	NUT, INSERT JAM 5/8-11	2
30	773040	WASHER, FLAT 3/8	4
31	773094	WASHER, FLAT 1/2 SAE	1
32	783935	OUTRIGGER ASSEMBLY 2000/2100	1
33	779905	CAP, 2" OD TUBE, BLACK	2
34	778383	LABLE KIT, 2100 SERIES	1
35	783552	STANDOFF-2112	2
36	771107	SCREW, HHC 3/8-16 X 1	4

LIFT UPPER AND LOWER MAST ASSEMBLY

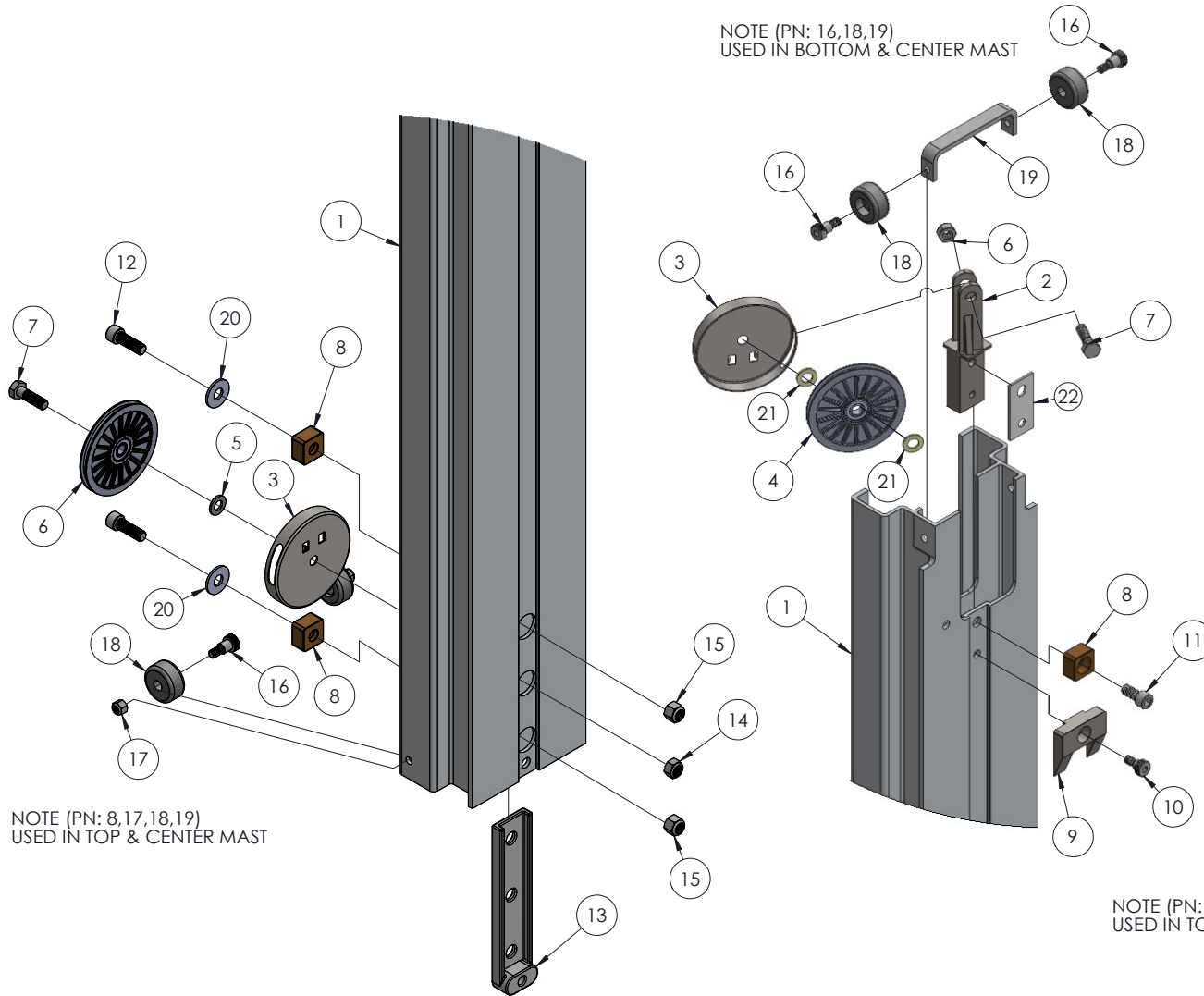

ITEM NO.	PART NUMBER	DESCRIPTION	QTY.
1	783661	UPPER MAST FABRICATION - 2100	1
1	783655	MAST FABRICATION - BOTTOM 2100	1
2	783489	TOP PULLEY MOUNT 2600 SERIES	1
3	783536	PULLEY GUARD	2
4	783921	PULLEY ASSY, ALUM 2000/2100 LIFTS	2
5	773096	WASHER, FLAT M12	1
6	772505	NUT, INSERT JAM M12	1
7	771161	SCREW, HHC M12-1.75 X 40	2
8	783575	STOP BLOCK	3
9	783694	STOP BLOCK WEDGE	1
10	771339	SCREW SHOULDER 1/2 X 1/4	1
11	771258	SCREW, SCH 1/2-13X 1"	1
12	771257	SCREW, SHC 1/2 - 13 X 1 - 1/2	2
13	783478	BACK PLATE WELDMENT	1
14	772800	NUT, INSERT LOCK 12MM	1
15	772357	NUT, INSERT LOCK 1/2 - 13	2
16	771350	SCREW, SHOULDER 1/2 X 1/2	4
17	772350	NUT, INSERT JAM 3/8 - 16	2
18	783540	MAST ROLLER	4
19	783649	TOP REINFORCEMENT BRACKET	1
20	773060	WASHER, FLAT 1/2 USS	2
21	773108	WASHER, FLAT 7/16" GRADE 8	2
22	783484	PLATE, TOP PULLEY MOUNT 2600	1

CARRIAGE ASSEMBLY

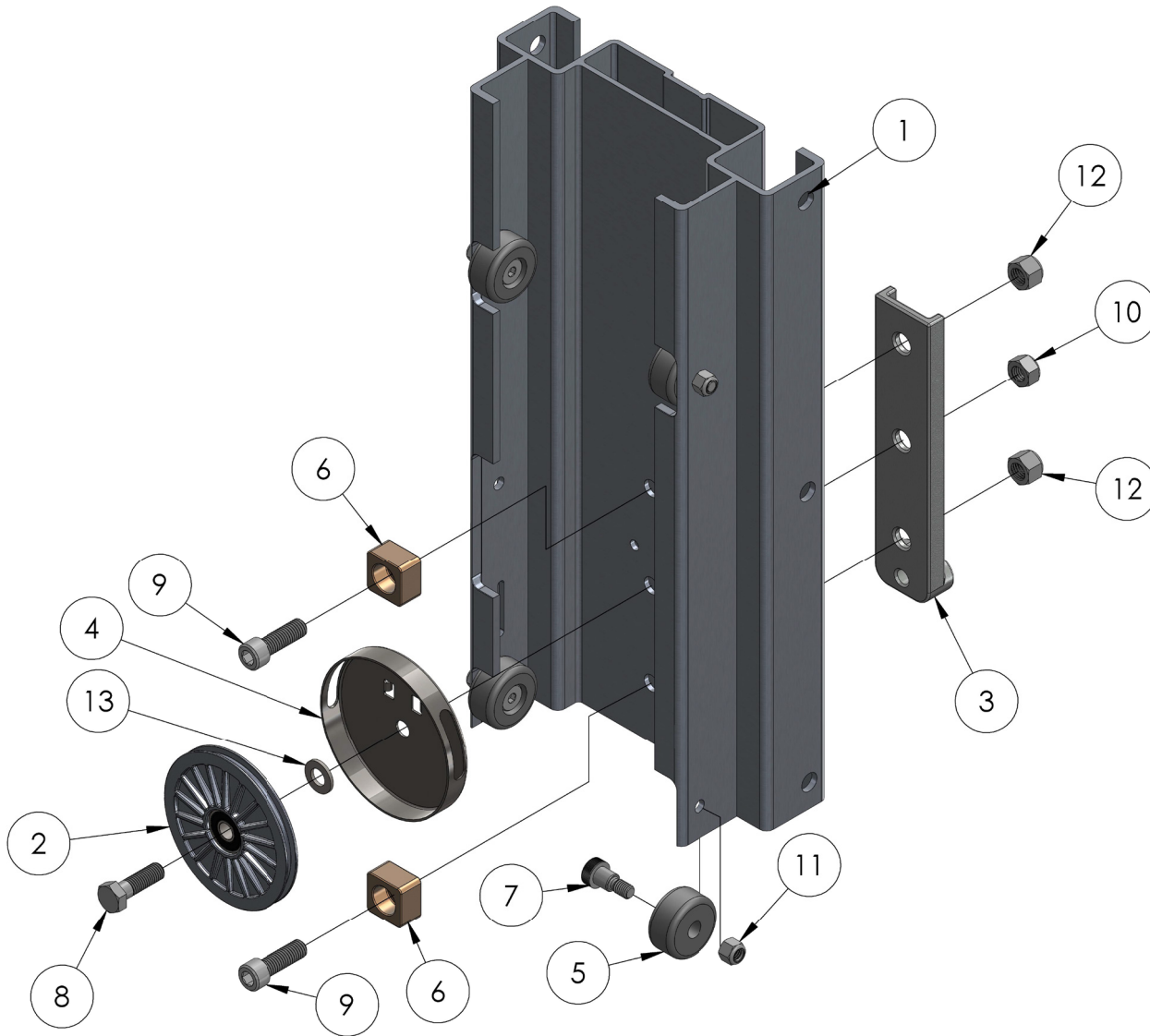

TORQUE STOP BLOCK TO 125 FT-LBS

ITEM NO.	PART NUMBER	DESCRIPTION	QTY.
1	783534	CARRIAGE	1
2	783921	PULLEY ASSY, ALUM 2000/2100	1
3	783478	BACKING PLATE	1
4	783536	PULLEY GUARD	1
5	783540	MAST ROLLER	4
6	783575	STOP BLOCK	2
7	771350	SCREW, SHOULDER 1/2 X 1/2	4
8	771161	SCREW, HHC M12 - 1.75 X 40	1
9	771257	SCREW, SHC 1/2-13 X 1-1/2	2
10	772800	NUT, INSERT LOCK 12MM	1
11	772350	NUT, INSERT JAM 3/8-16	4
12	772357	NUT, INSERT LOCK 1/2-13	2
13	773096	WASHER, FLAT M12	1

BRAKE CAM AND WEIGHT ASSEMBLY

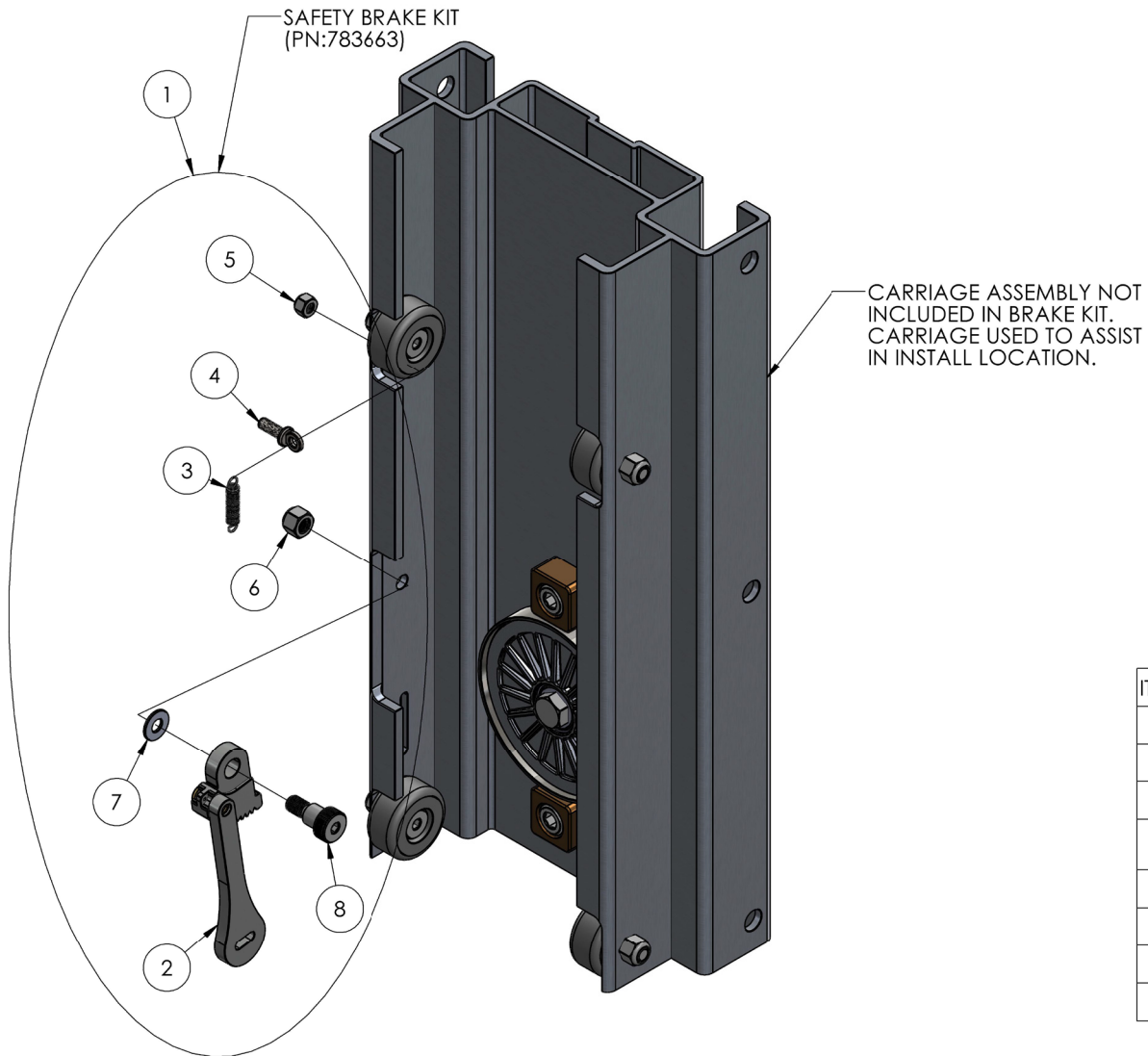

ITEM NO.	PART NUMBER	DESCRIPTION	QTY.
1	783663	SAFETY BRAKE ASSEMBLY	1
2	783692	BRAKE CAM AND WEIGHT ASSEMBLY	1
3	783530	BRAKE SPRING	1
4	779900	SCREW, ADJUSTING (OHIO ES2112) EYE BOLT	1
5	772076	NUT, INSERT LOCK 1/4-20	1
6	772350	NUT, INSERT JAM 3/8 - 16	1
7	773042	WASHER, FLAT 5/16	1
8	771350	SCREW, SHOULDER 1/2 X 1/2	1

FORK ASSEMBLY

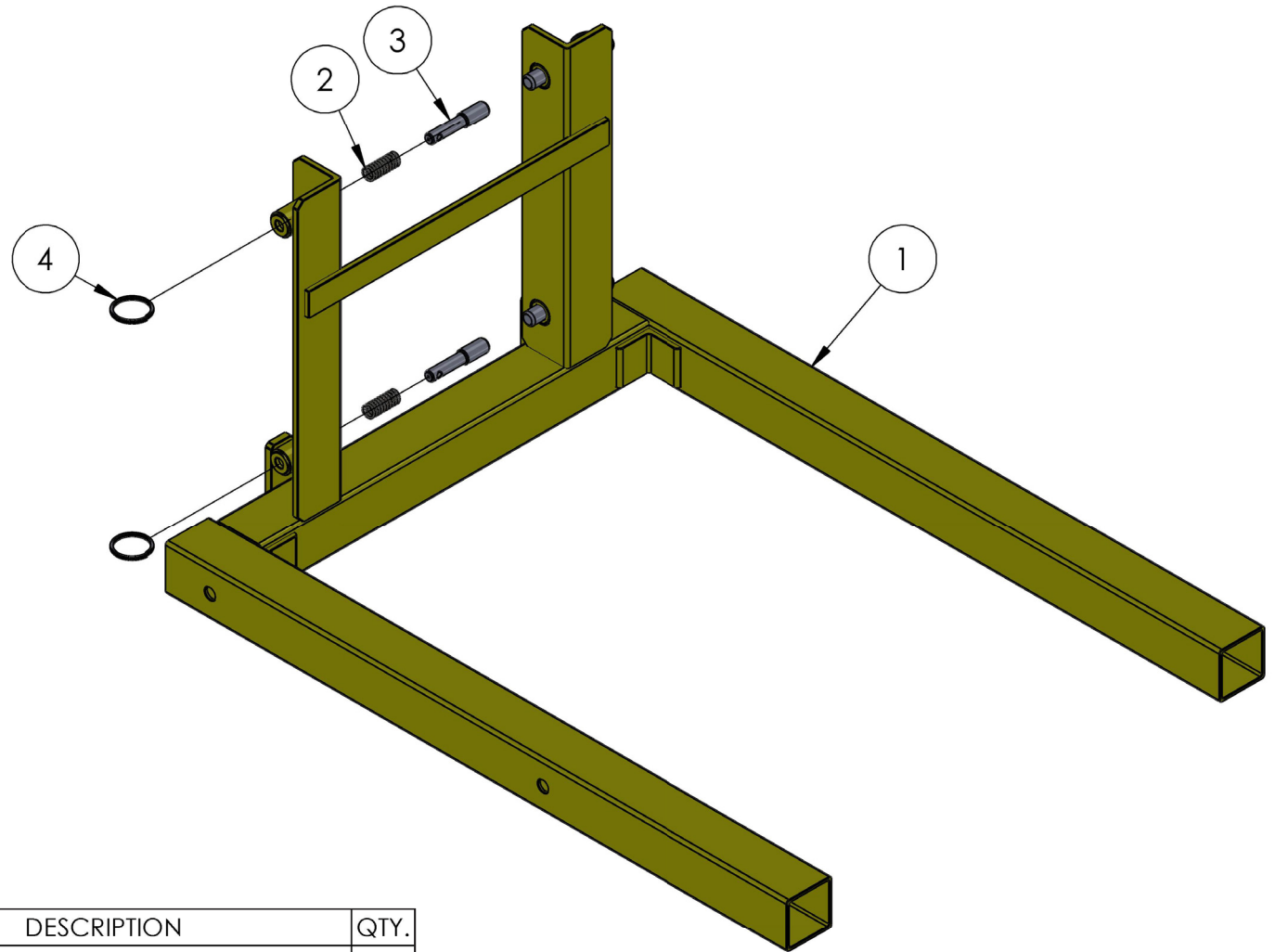

ITEM NO.	PART NUMBER	DESCRIPTION	QTY.
1	783547	FORK WELDMENT, 2000/2100 LIFT	1
1	783496	FORK WELDMENT GALV	1
2	776212	SPRING, #DWC - 042 - G - 9	4
3	782510	PLUNGER	4
4	775110	SPLIT RING 1-1/4" NICKEL PLATED	4

FORK EXTENSION INSTALL KIT ASSEMBLY

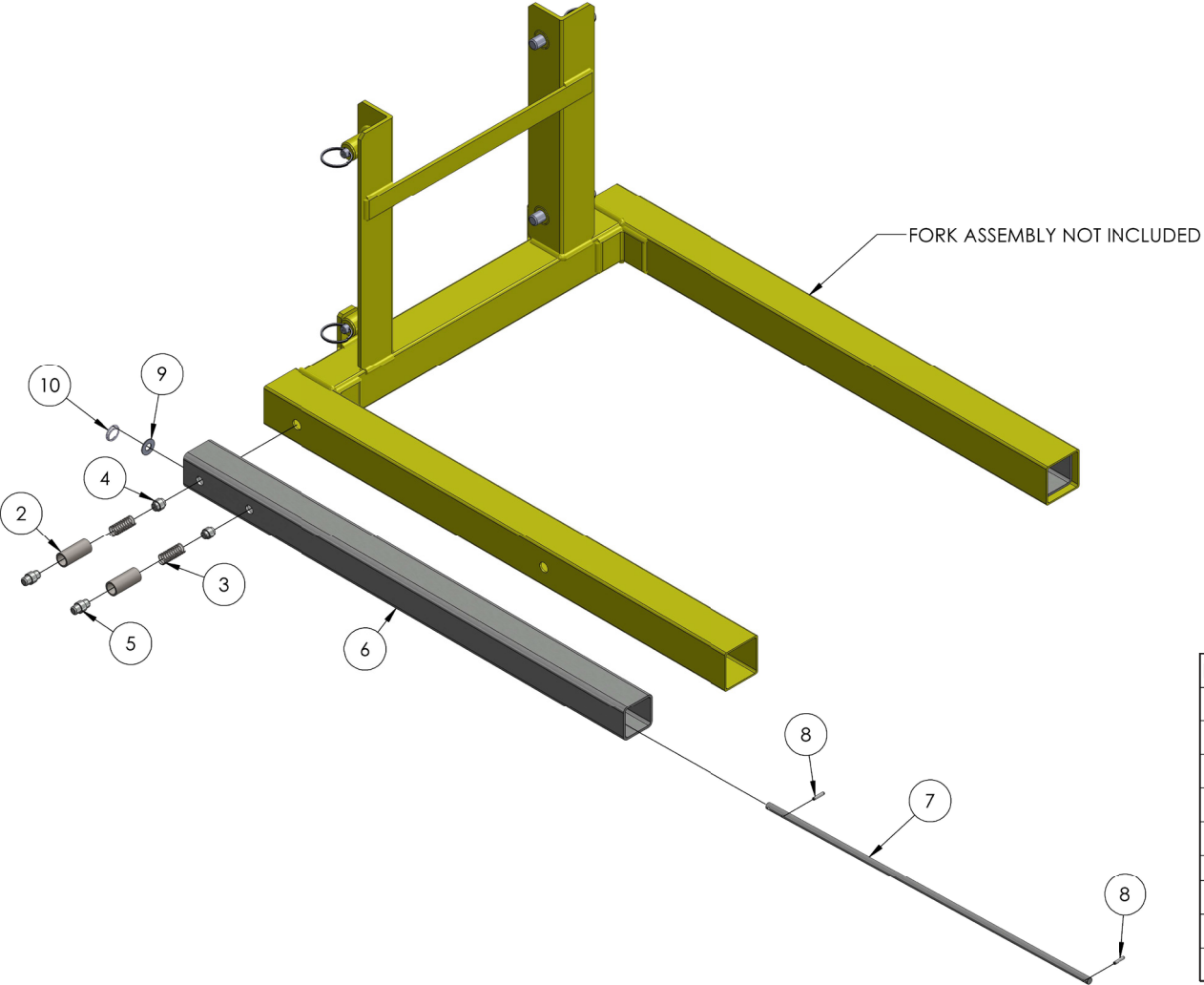

ITEM NO.	PART NUMBER	DESCRIPTION	QTY.
2	774035	SPACER, BUTTITE 1/2 X 1.453"	4
3	776212	SPRING, #DWC - 042 - G - 9	4
4	783508	PIN LOCATOR	4
5	783509	PIN DETENT	4
6	783588	FORK EXTENSION WELDMENT	2
7	783789	FORK EXTENSION LIMIT ROD, 2000/2100	2
8	774092	PIN, ROLL 1/8 X 6.25	4
9	773042	WASHER, FLAT 5/16	2
10	774053	COTTER, CIRCLE Z/P 0.048 X 0.75	2

BASE ASSEMBLY

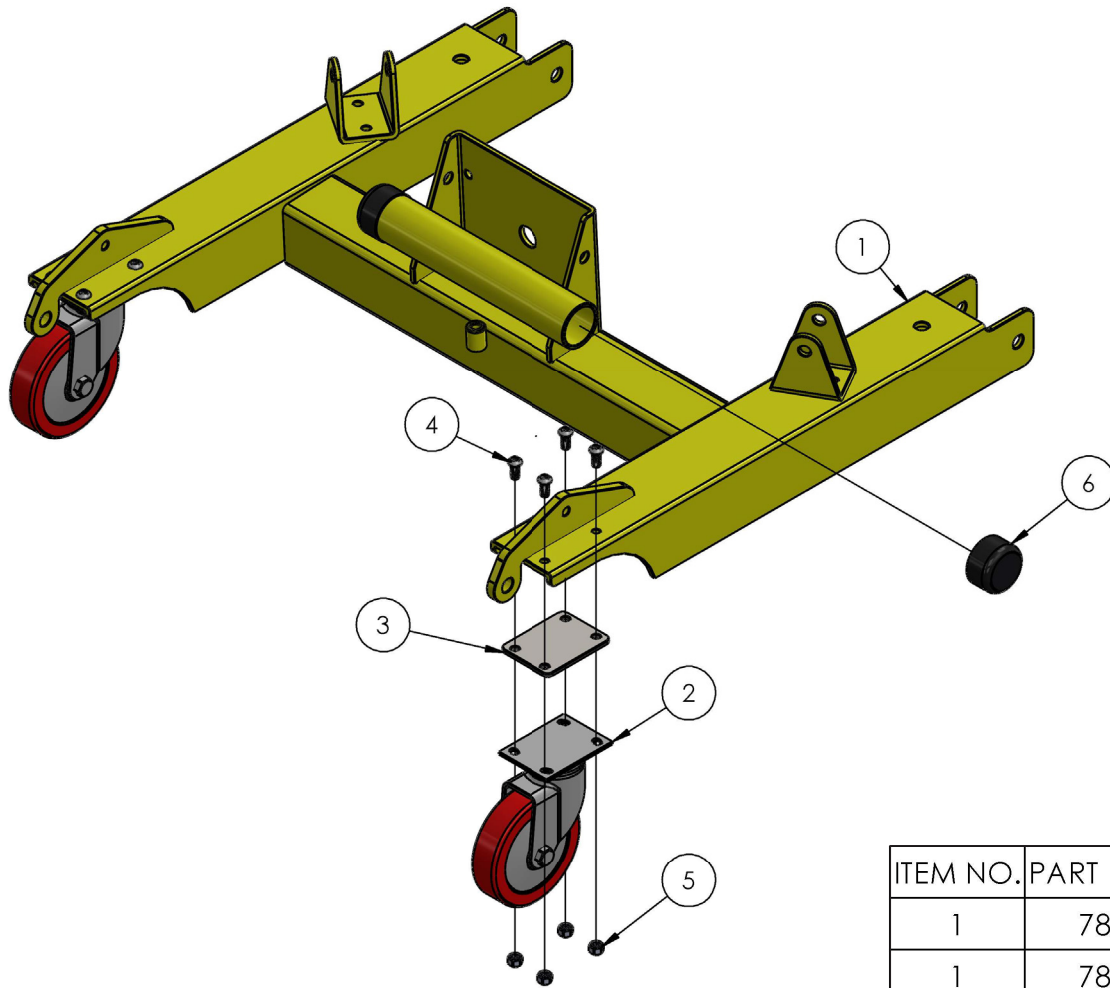

ITEM NO.	PART NUMBER	DESCRIPTION	QTY.
1	783749	BASE WELDMENT, 2100 SERIES	1
1	783499	BASE WELDMENT, 2100 SERIES GALV	1
2	779005	CASTER, 5" PLATE SWIVEL (RED)	2
3	783098	SPACER 2-3/4 X 3-34 X 1/8" THK	2
4	771269	SCREW, BHC 5/16-18 X 0.75	8
5	772502	NUT, INSERT JAM 5/16-18	8
6	779905	CAP, 2" OD TUBE, BLACK	2

FRONT LEG WELDMENT ASSEMBLY

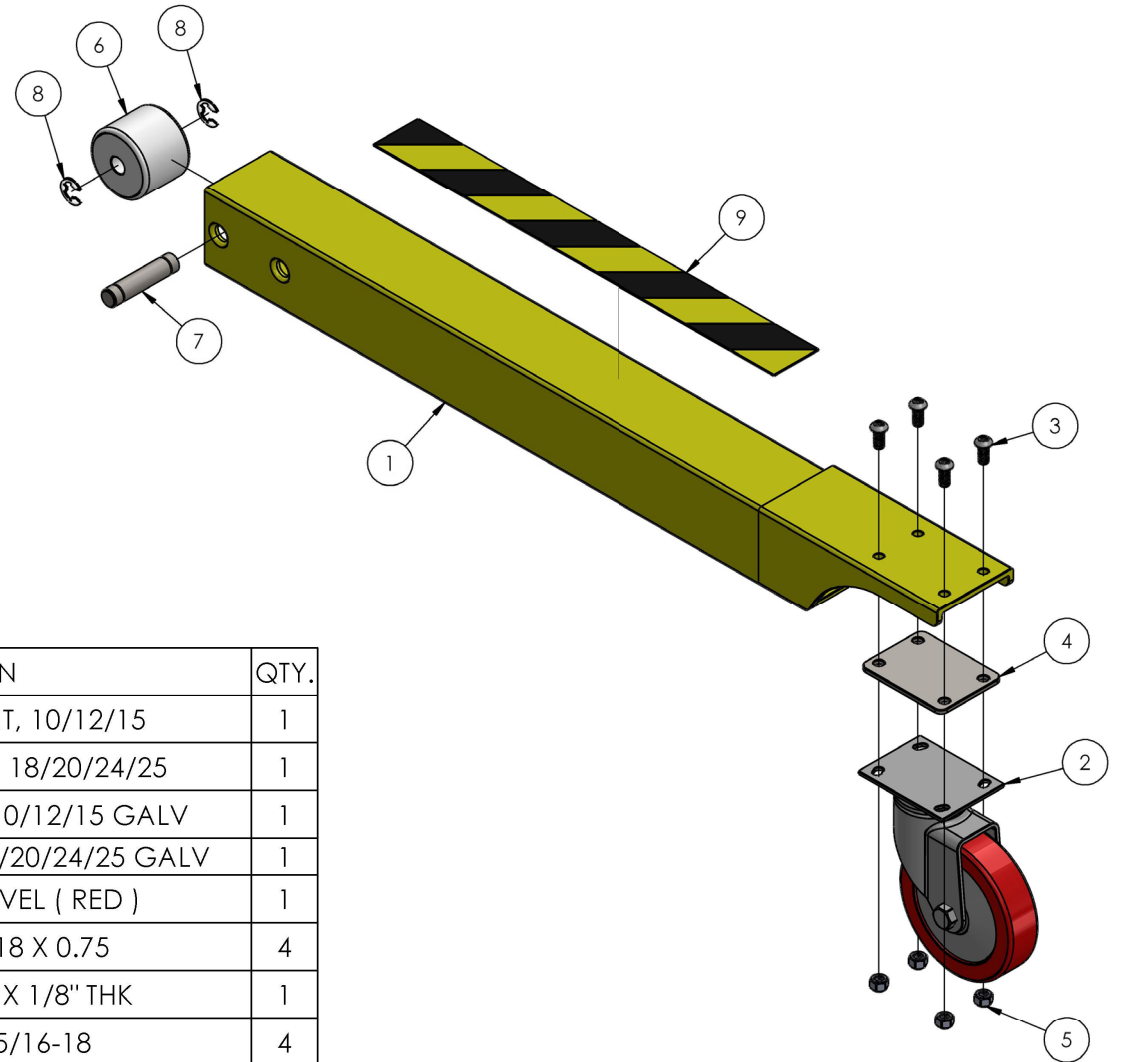

ITEM NO.	PART NUMBER	DESCRIPTION	QTY.
1	783732	FRONT LEG WELDMENT, 10/12/15	1
1	783738	FRONT LEG WELDMENT, 18/20/24/25	1
1	783498	FRONT LEG WELDMENT, 10/12/15 GALV	1
1	783497	FRONT LEG WELDMENT, 18/20/24/25 GALV	1
2	779005	CASTER, 5" PLATE SWIVEL (RED)	1
3	771269	SCREW, BHC 5/16-18 X 0.75	4
4	783098	SPACER 2-3/4 X 3-34 X 1/8" THK	1
5	772502	NUT, INSERT JAM 5/16-18	4
6	783569	ROLLER LEG	1
7	783644	SHAFT, LEG ROLLER	1
8	776077	RETAINER RING #5133-62	2
9	778352	TAP, 2" B/Y CAUTION STRIP (SEE NOTE)	1

OUTRIGGER ASSEMBLY

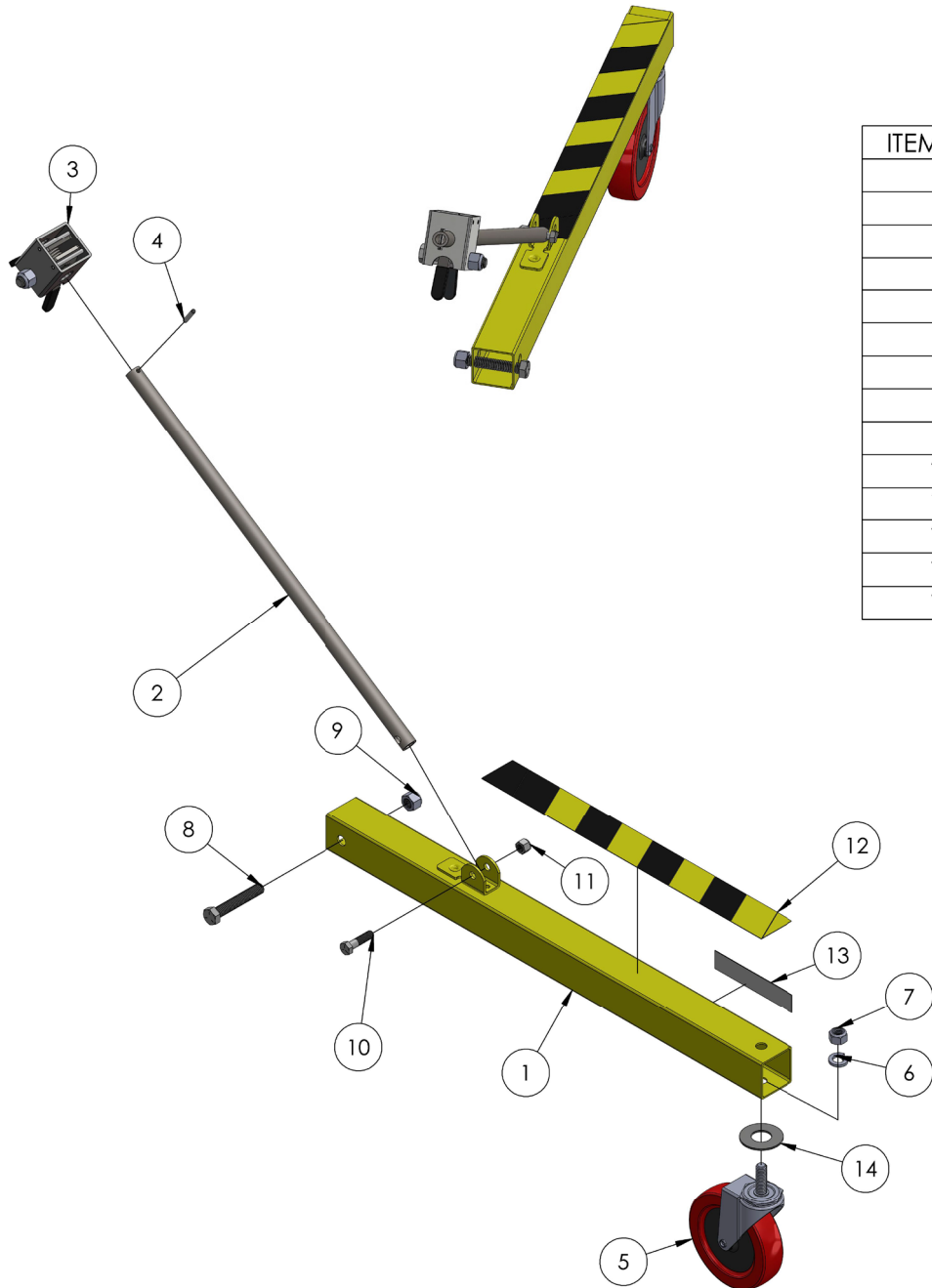

ITEM NO.	PART NUMBER	DESCRIPTION	QTY.
1	783528	LEG WELDMENT, OUTRIGGER	2
2	783938	OUTRIGGER SUPPORT TUBE, 2500	2
3	783940	OUTRIGGER LOCK ASSEMBLY	2
4	774080	PIN ROLL 3/16 X 1.0" LN	2
5	779002	CASTER, 125 X 32 12MM STEM	2
6	773590	WASHER, LOCK 1/2	2
7	772801	NUT, HEX 12MM ZINC PLATED	2
8	771142	SCREW, HHC 1/2-13 X 3	2
9	772358	NUT, INSERT JAM 1/2 -13	2
10	771090	SCREW, HHC 3/8-16 X 1.5"	2
11	772350	NUT, INSERT JAM 3/8 - 16	2
12	778352	TAPE, 2" B/Y CAUTION STRIP (SEE NOTE)	2
13	778348	LABEL, LOWER STABELIZER LEG	2
14	773091	WASHER, FLAT 7/8" USS PLATED	2

NL WINCH ASSEMBLY

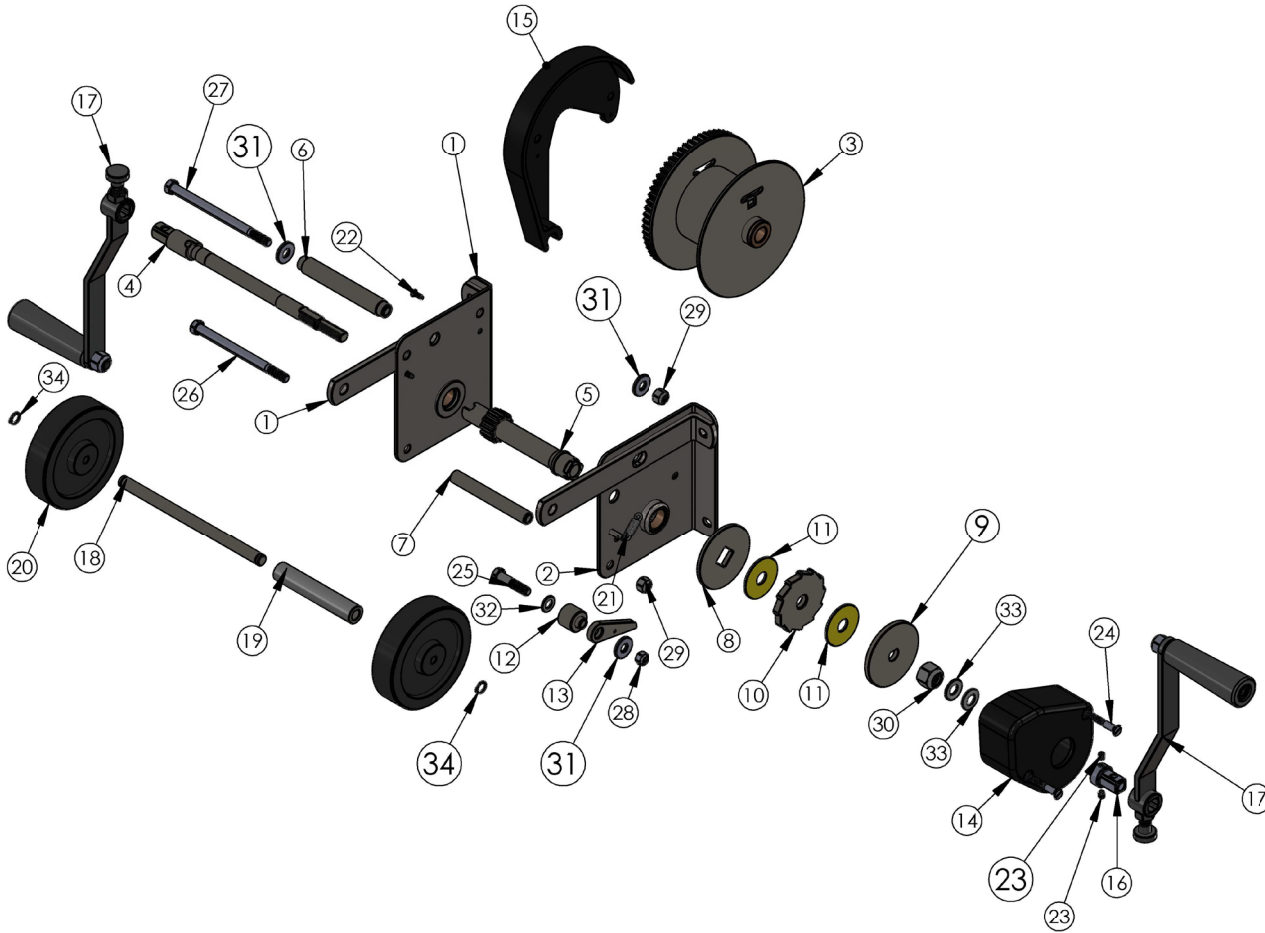

ITEM NO.	PART NUMBER	DESCRIPTION	QTY.
1	784492	SIDE PLATE ASSEMBLY-LH, NL WNCH	1
2	784494	SIDE PLATE ASSEMBLY-RH, NL WNCH	1
3	783613	DRUM ASSEMBLY	1
4	783754	DRIVE SHAFT NL WINCH	1
5	784500	SHAFT, HOIST DRUM PINION, SQ END	1
6	783606	DRUM SPACER SHAFT	1
7	783599	SPACER-WINCH SIDE PLATE	1
8	784498	PLATE, INNER BRAKE DISC, NL WINCH	1
9	780212	PLATE, OUTER BRAKE DISC, NL WINCH	1
10	780214	BRAKE RATCHET WJ-15	1
11	783615	BRAKE DISK	2
12	783598	SPACER-RATCHET	1
13	780216	HOIST RATCHET DOG WJ-19	1
14	783612	BRAKE COVER	1
15	783611	GEAR COVER	1
16	784284	WINCH HANDLE ADAPTER	1
17	783757	WINCH HANDLE	2
18	782619	WINCH SHAFT, ROLLER	1
19	783764	SLEEVE, ROLLER SHAFT	1
20	779045	5" PLASTIC WHEEL	2
21	783621	RATCHET DOG SPRING	1
22	776042	SCREW, BHMS #8-32 X 1/2" LN	2
23	771431	SET SCREW 1/4-20 X 5/16"LN FLT PT	2
24	771290	SCREW, FHSC 1/4-20 X 2.25"LN	2
25	771100	SCREW, HHC 3/8-16X1.75" LN	1
26	771111	SCREW, HHC 3/8-16X5.5" LN	1
27	771105	SCREW, HHC 3/8-16X6" LN	1
28	772502	NUT, INSERT JAM 5/16-18	1
29	772355	NUT, INSERT LOCK 3/8-16	2
30	772375	NUT, INSERT JAM 5/8-16	1
31	773040	WASHER, FLAT 3/8"	3
32	773631	WASHER, FLAT 3/8"	1
33	773085	WASHER, BELLEVILLE 1/2"	2
34	776072	RING, EXTERNAL RETAINING 1/2"	2

MAST HOLD DOWN ASSEMBLY

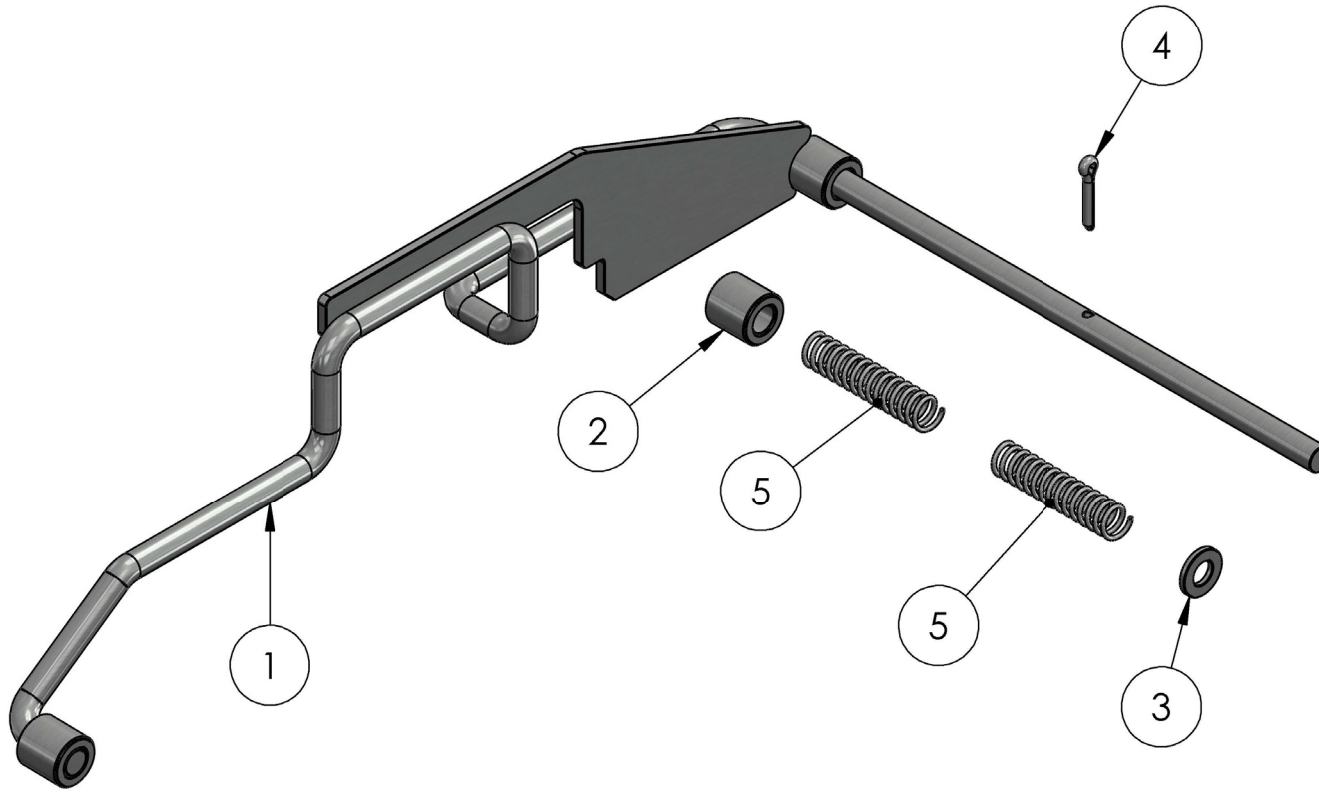

ITEM NO.	PART NUMBER	DESCRIPTION	QTY.
1	783041	MAST HOLD DOWN DEVICE WELDMENT	1
2	783044	MAST HOLD DOWN SPACER	1
3	773096	WASHER, FLAT M12	1
4	774051	PIN, COTTER 0.125 X 0.75"	1
5	776216	SPRING, CENTURY #71912S	2

SPREADER PLATE ASSEMBLY

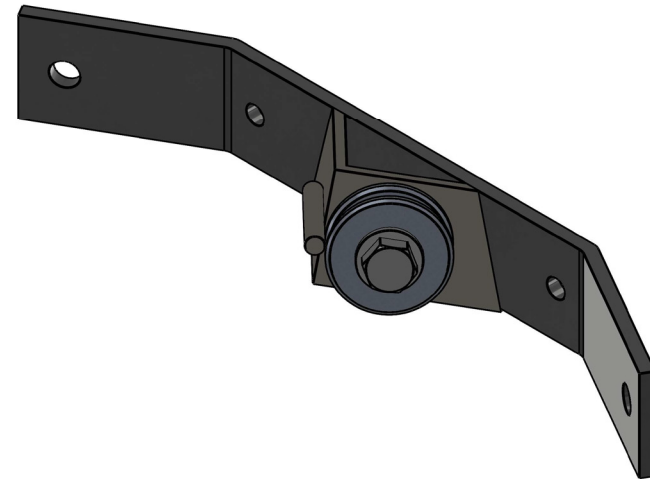
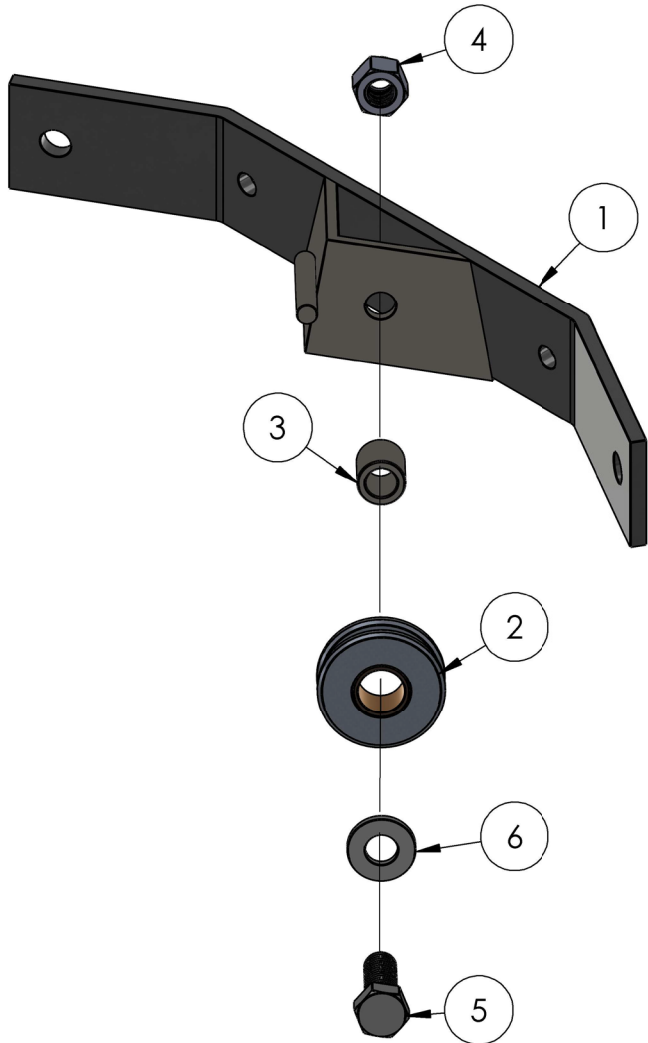

ITEM NO.	PART NUMBER	DESCRIPTION	QTY.
1	783581	SPREADER PLATE WELDMENT	1
2	780025	SHEAVE, RAB-222 (2"") Z-22	1
3	782960	ROLLER SHAFT, CARR.715/720	1
4	772358	NUT, INSERT JAM 1/2 -13	1
5	771120	SCREW, HHC 1/2-13 x 1.5" LN	1
6	773094	WASHER, FLAT 1/2 SAE	1

10" WHEEL KIT ASSEMBLY

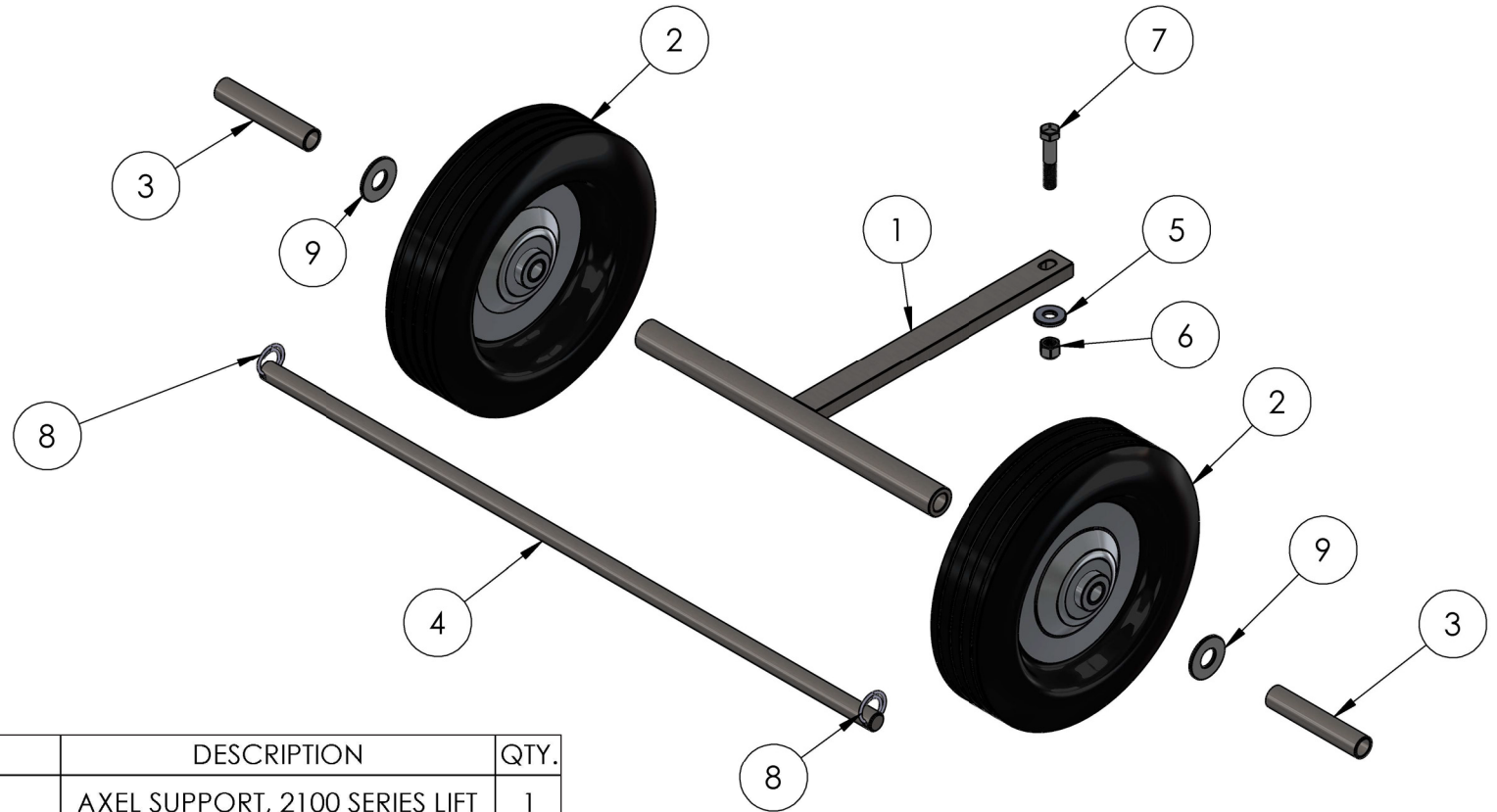

ITEM NO.	PART NUMBER	DESCRIPTION	QTY.
1	783735	AXEL SUPPORT, 2100 SERIES LIFT	1
2	779011	WHEEL, 10" RUBBER TIRE	2
3	774039	SPACER, BUTTITE 5/8 X 4"	2
4	782544	AXLE, MODEL 209	1
5	773040	WASHER, FLAT 3/8"	1
6	772355	NUT, INSERT LOCK 3/8-16	1
7	771112	SCREW, HHC 3/8-16 X 2	1
8	774054	COTTER, CIRCLE Z/P 0.072 X 1.125"	2
9	773051	WASHER, FLAT 5/8 USS	2

LEG LOCK ASSEMBLY

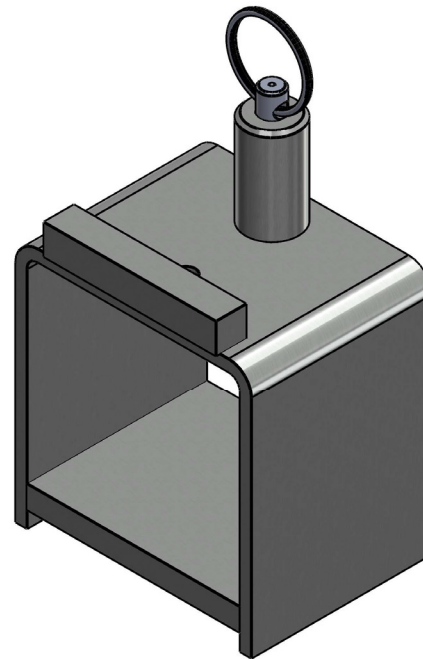
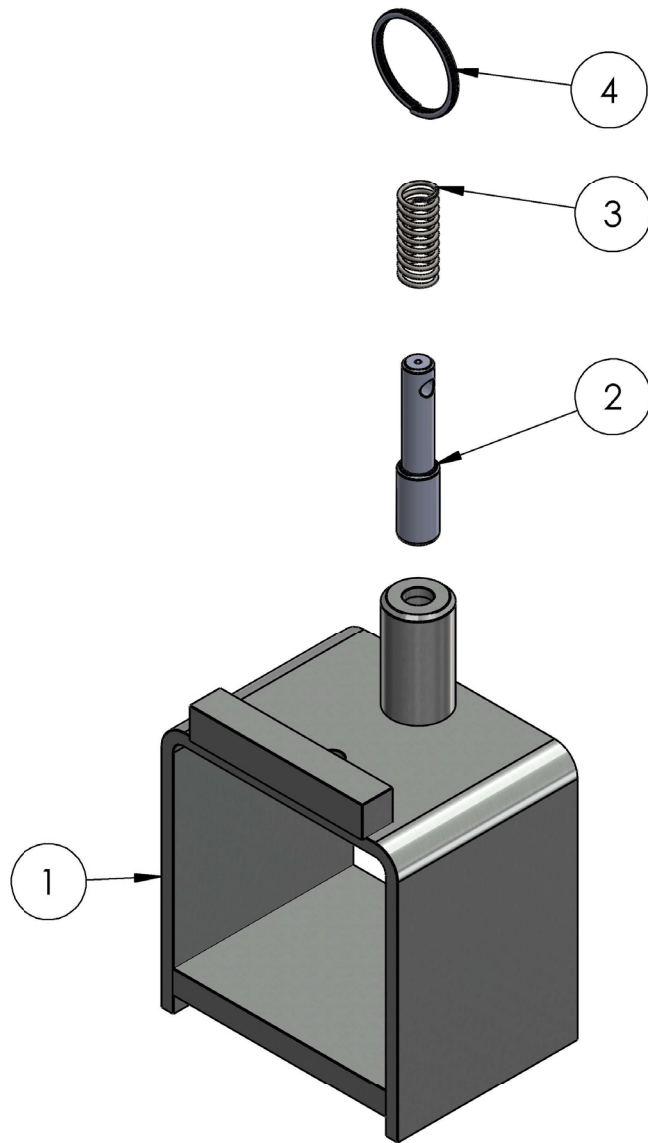

ITEM NO.	PART NUMBER	DESCRIPTION	QTY.
1	783740	LEG LOCK WELDMENT, 2100 SERIES	1
2	782510	PLUNGER	1
3	776212	SPRING, #DWC - 042 - G - 9	1
4	775110	SPLIT RING 1-1/4" NICKEL PLATED	1

WINCH HANDLE ASSEMBLY

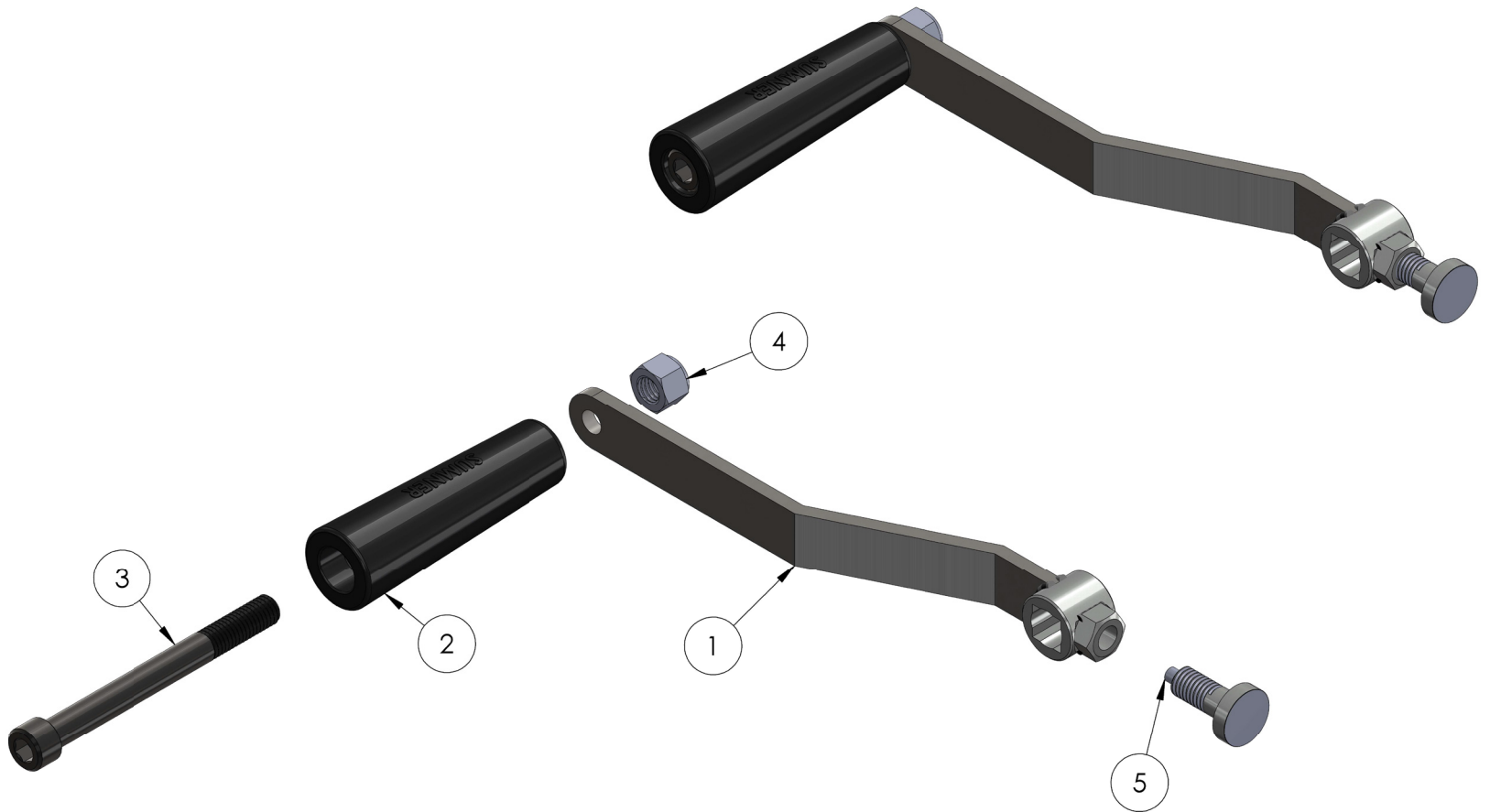

ITEM NO.	PART NUMBER	DESCRIPTION	QTY.
1	783756	WINCH HANDLE WELDMENT	1
2	780182	WINCH HANDLE SLEEVE	1
3	771254	SCREW, SHC 1/2 -13 X 5"LN	1
4	772358	NUT, INSERT JAM 1/2 -13	1
5	774180	SPRING PLUNGER,M 1/4 DIA.	1

OUTRIGGER LOCK TUBE ASSEMBLY

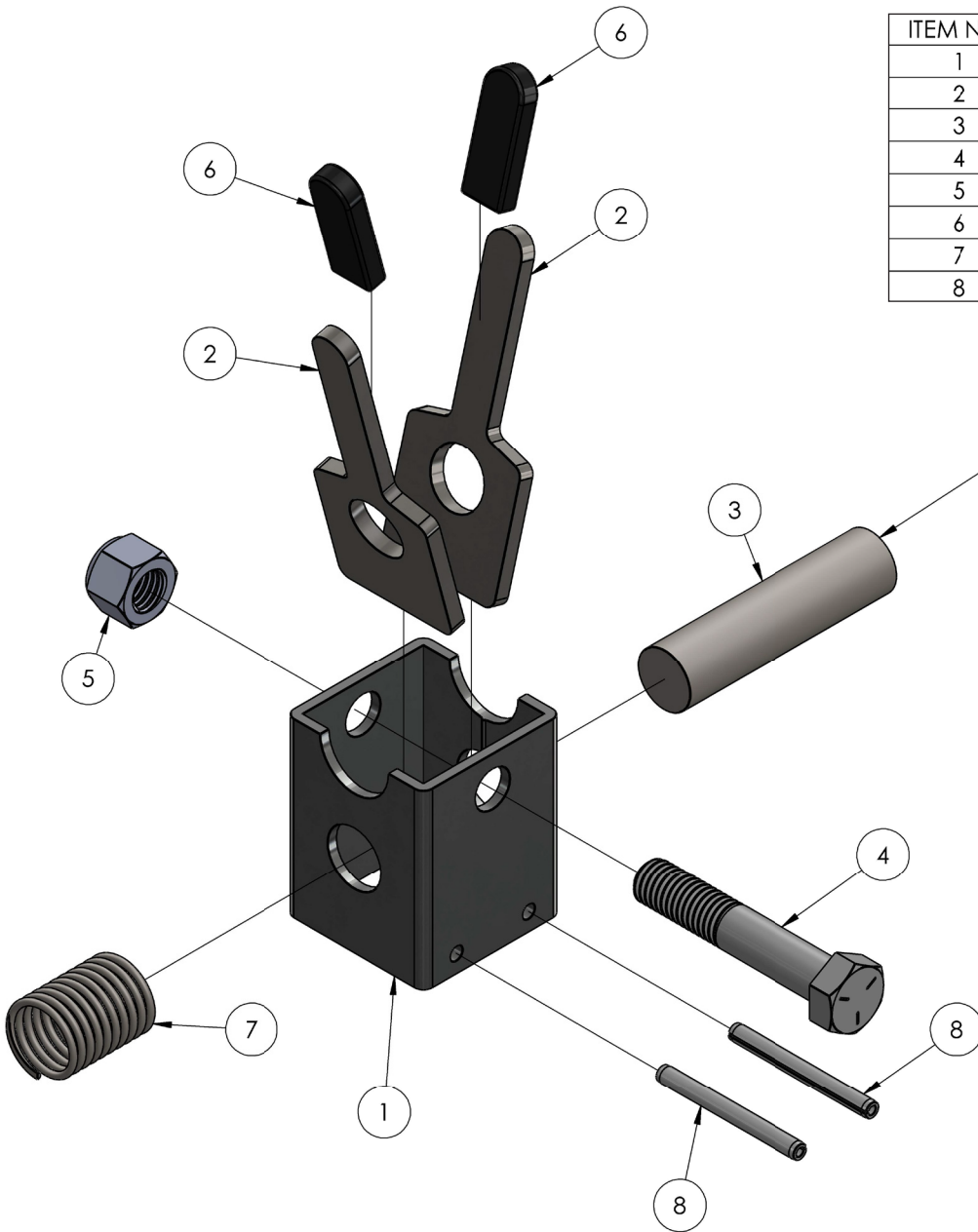

ITEM NO.	PART NUMBER	DESCRIPTION	QTY.
1	783941	OUTRIGGER LOCK TUBE	1
2	783942	OUTRIGGER LOCK FINGER	2
3	783944	OUTRIGGER SUPPORT TUBE STUB	1
4	771141	SCREW, HHC 1/2-13X2.75" LN	1
5	772358	NUT, INSERT JAM 1/2 -13	1
6	779938	CAP, RECT RD END 3/16X0.5X2.0"	2
7	776221	CENTURY SPRING #2952	1
8	774084	PIN, SPRING 3/16X2.0"	2

OUTRIGGER SUPPORT TUBE STUB LOCKS ASSEMBLY IS INSTALLED TO SUPPORT THE ASSEMBLY DURING SHIPMENT AND IS TO BE DISCARDED BEFORE INSTALLATION.

OUTRIGGER SUPPORT TUBE ASSEMBLY

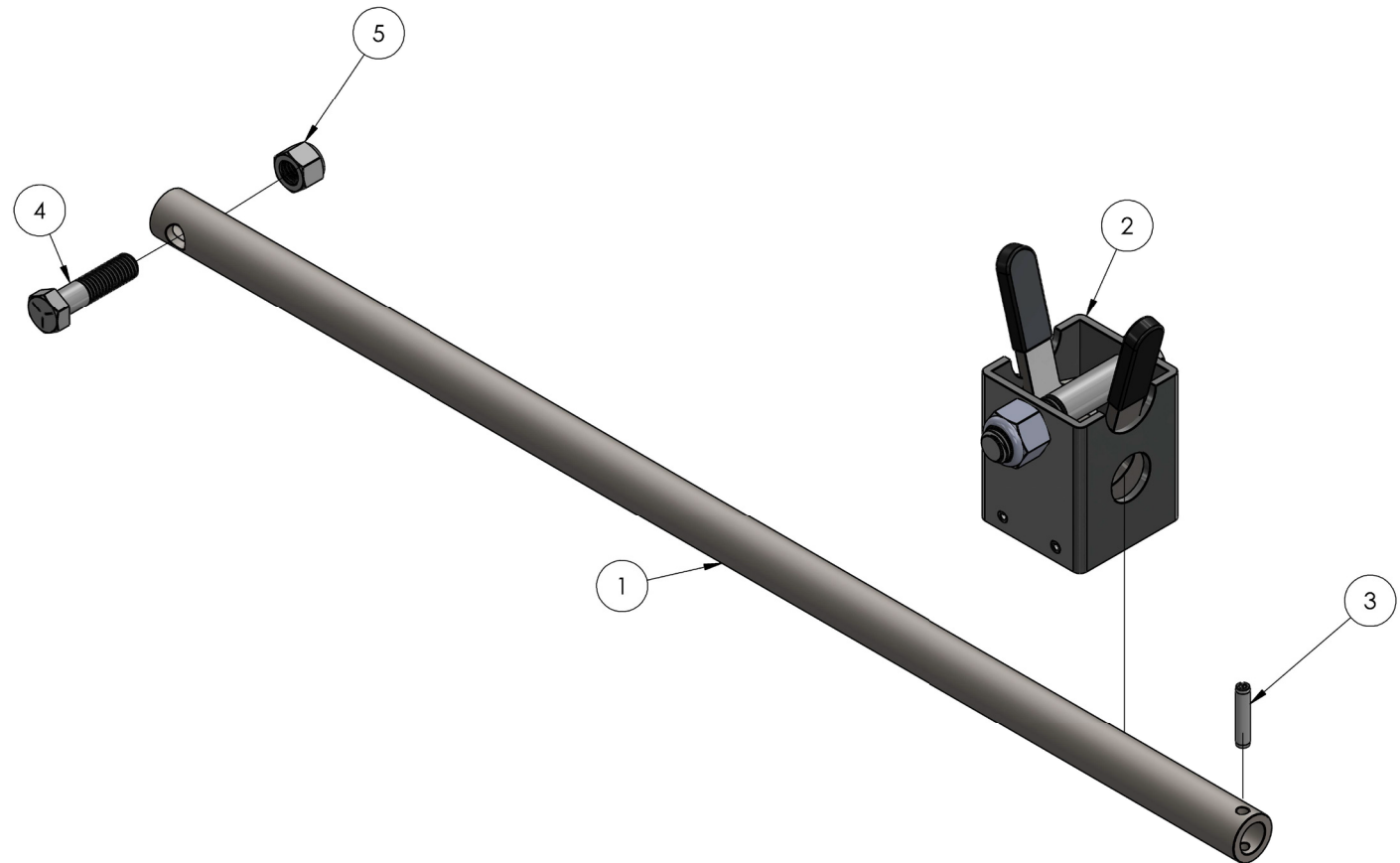

ITEM NO.	PART NUMBER	DESCRIPTION	QTY.
1	783938	OUTRIGGER SUPPORT TUBE, 2500	1
2	783940	OUTRIGGER LOCK ASSEMBLY	1
3	774080	PIN ROLL 3/16 X 1.0" LN	1
4	771090	SCREW, HHC 3/8-16 X 1.5"	1
5	772350	NUT, INSERT JAM 3/8 - 16	1