

SERIES 2500 COUNTER WEIGHT LIFT

APPLICATIONS

- No front legs to interfere with lifting
- Cart & mast section breakdown for ease of transportation
- 650 - 1,000 lbs (300 - 455 kg) lifting capacity
- Great for hanging pipe against wall
- Four heights 10' - 25' (3 - 7 m)
- 2 speed winch
- Can reach up to second floor
- Works around ground obstructions
- Great for next to wall applications
- Cart & base assemble with quick action attaching plunger pins.
- Adjustable base leveling screw to accommodate base extensions on unlevel floors
- Mast lifting eye
- Pulleys fully enclosed to retain cable

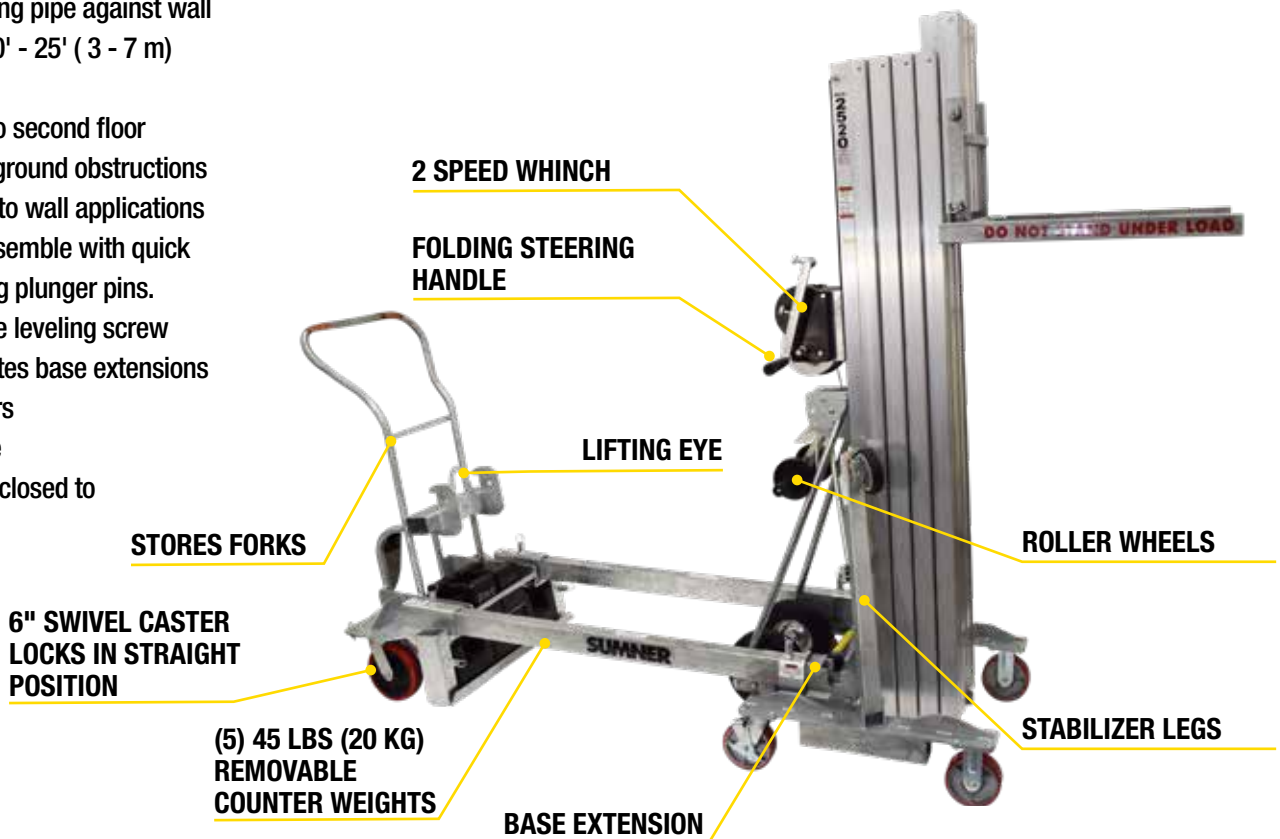

PART #	DESCRIPTION	GROUND CLEARANCE	LOAD HEIGHT MIN	MAX HEIGHT FORKS DOWN	MAX HEIGHT FORKS UP	WEIGHT	SAFETY BRAKE OPTION
786510	2510 Counter Weight Lift	2-1/2" (6.4 cm)	6" (15.2 cm)	9' 8-1/2" (2.9 m)	11' 8-1/4" (3.6 m)	644 lbs (292.7 kg)	783882
786511	2515 Counter Weight Lift	2-1/2" (6.4 cm)	6" (15.2 cm)	14' 4" (4.3 m)	16' 3-1/2" (4.9 m)	681 lbs (314.1 kg)	783883
786512	2520 Counter Weight Lift	2-1/2" (6.4 cm)	6" (15.2 cm)	18' 10" (5.7 m)	21' (6.4 m)	738 lbs (355.5 kg)	783884
786513	2525 Counter Weight Lift	2-1/2" (6.4 cm)	6" (15.2 cm)	23' 5-3/8" (7.1 m)	25' 7-3/8" (7.8 m)	785 lbs (356.8 kg)	783885

SERIES 2500 COUNTER WEIGHT LIFT ACCESSORIES



FORK EXTENSION (# 784695)

With the push of a button, forks may be extended from 23-1/4" (59.2 cm) to 29-7/16" (75.7 cm). When using the fork extensions the weight capacity reduces to 200 lbs (90 kg), as is clearly marked on the extended forks. A second button returns the extension for storage inside forks.



BOOM CARRIAGE (# 786645)

Works well with glass lifting machinery.



PIPE CRADLE (# 783705)

Great for air ducts or other HVAC applications. Slides over forks. Packaged two per set.

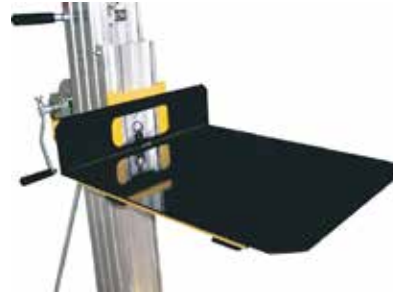

STEEL TRAY (# 784320)

24" x 24" (61 x 71 cm) steel tray slides onto forks.

PART #	DESCRIPTION
783882	2510 Safety Brake Option
783883	2515 Safety Brake Option
783884	2520 Safety Brake Option
783885	2525 Safety Brake Option

OPTIONAL SAFETY BRAKES

Each mast and carriage can have a factory installed, gravity actuated safety brake which holds loads in place to help avoid any slack in the cable.