

## SERIES 2500 COUNTER WEIGHT LIFT

### APPLICATIONS

- No front legs to interfere with lifting
- Cart & mast section breakdown for ease of transportation
- 650 - 800 lbs (300 - 363 kg) lifting capacity
- Great for hanging pipe against wall
- Three heights 15' – 25' (4.3m – 7m)
- 2 speed winch
- Can reach up to second floor
- Works around ground obstructions
- Great for next to wall applications
- Cart & base assemble with quick action attaching plunger pins.
- Adjustable base leveling screw to accommodate base extensions on unlevel floors
- Pulleys fully enclosed to retain cable

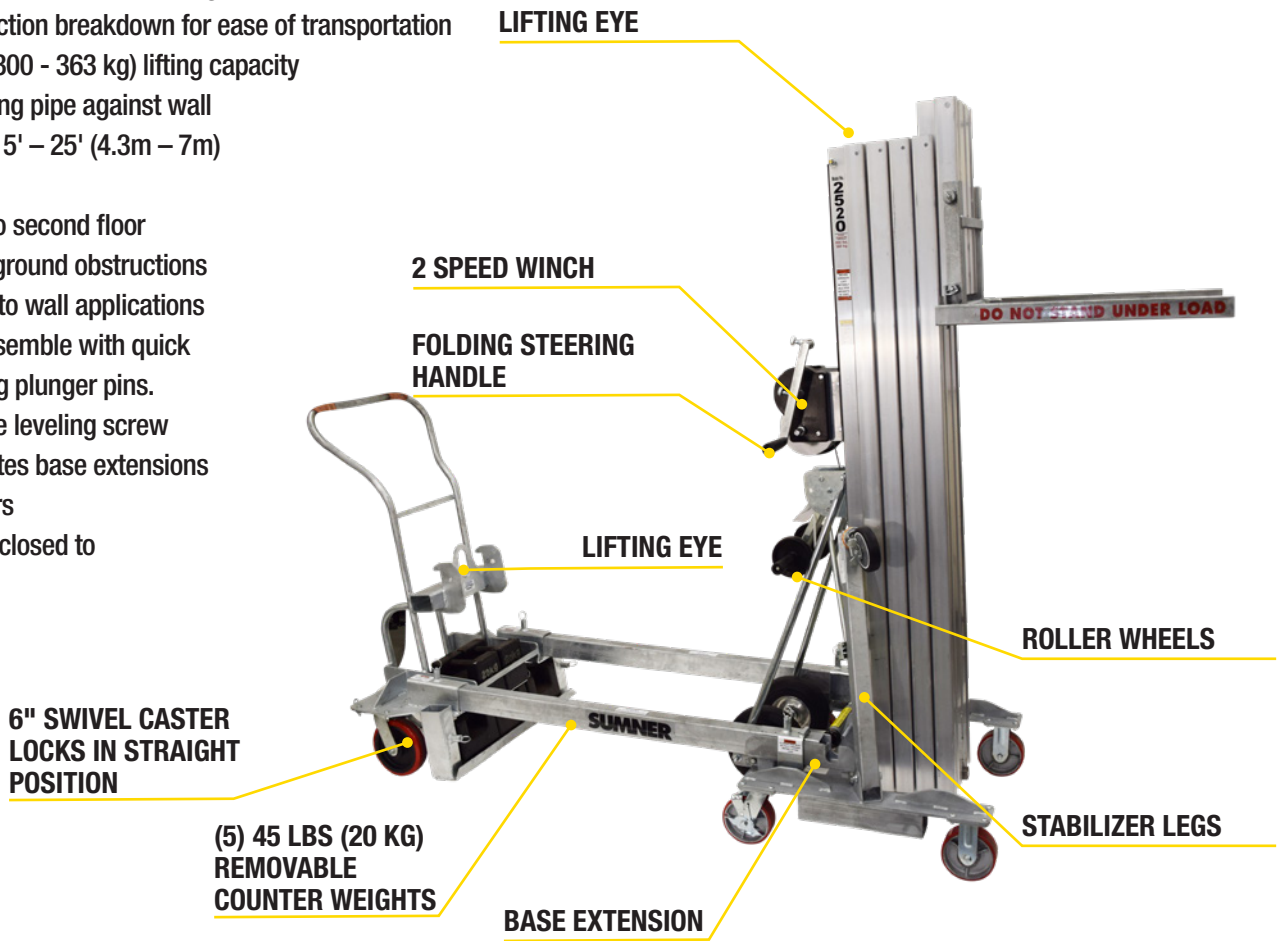

| PART # | DESCRIPTION              | GROUND CLEARANCE | LOAD HEIGHT MIN | MAX HEIGHT FORKS DOWN | MAX HEIGHT FORKS UP | WEIGHT             |
|--------|--------------------------|------------------|-----------------|-----------------------|---------------------|--------------------|
| 786511 | 2515 Counter Weight Lift | 2-1/2" (6.4 cm)  | 6" (15.2 cm)    | 14' 4" (4.3 m)        | 16' 3-1/2" (4.9 m)  | 681 lbs (314.1 kg) |
| 786512 | 2520 Counter Weight Lift | 2-1/2" (6.4 cm)  | 6" (15.2 cm)    | 18' 10" (5.7 m)       | 21' (6.4 m)         | 738 lbs (355.5 kg) |
| 786513 | 2525 Counter Weight Lift | 2-1/2" (6.4 cm)  | 6" (15.2 cm)    | 23' 5-3/8" (7.1 m)    | 25' 7-3/8" (7.8 m)  | 785 lbs (356.8 kg) |

## SERIES 2500 COUNTER WEIGHT LIFT ACCESSORIES



### PIPE CRADLE (# 783705)

Great for air ducts or other HVAC applications. Slides over forks. Packaged two per set.



### BOOM CARRIAGE (# 786645)

Works well with glass lifting machinery.

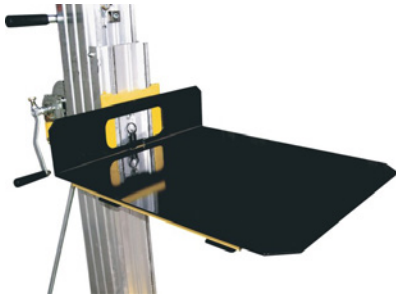

### STEEL TRAY (# 786320)

24" x 24" (61 x 71 cm) steel tray slides onto forks.