

SIDES	BOTTOM
Material: Steel- $\varnothing 0.16''$ -(C1008-C1018) Zinc Plated	

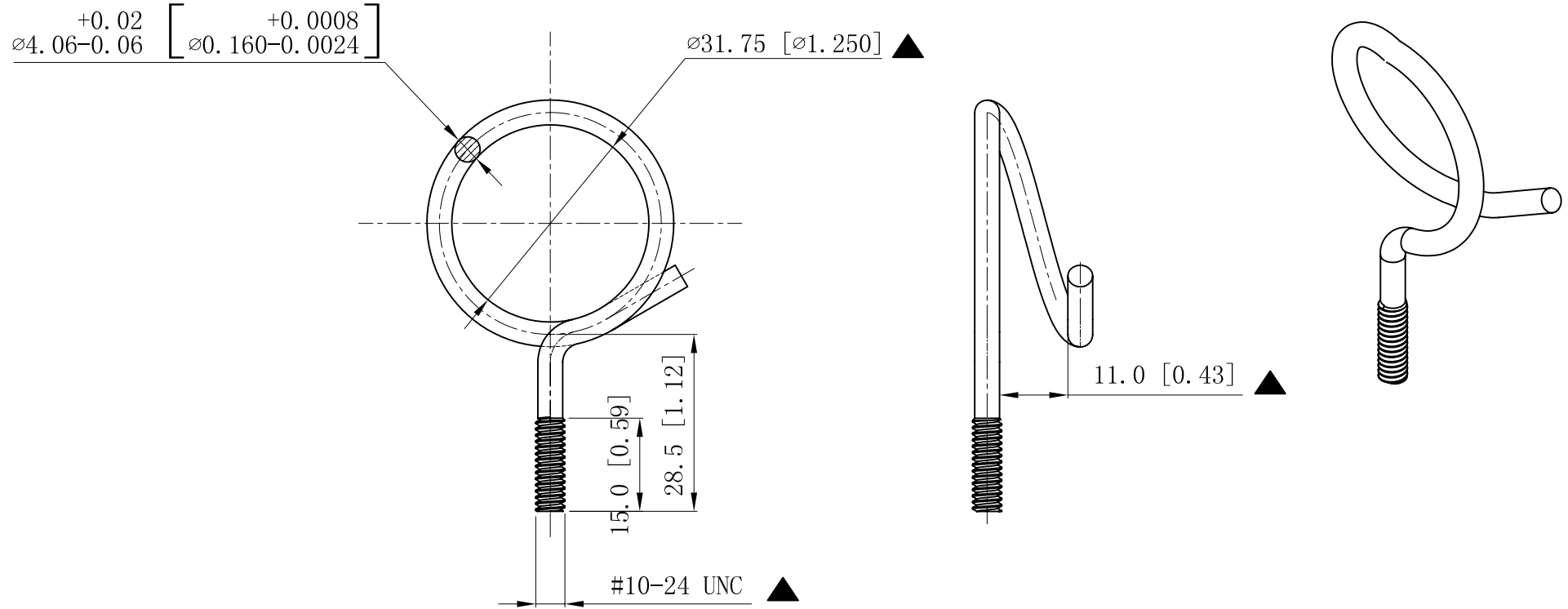

This data sheet is for reference only .GARVIN INDUSTRIES reserves the right to make changes to the design without prior notice.

DESCRIPTION
TRADE REFERENCE TERMS

STANDARD PACKING
100 PCS

<b>GARVIN INDUSTRIES</b>		
TITLE MACHINE-SCREW BRIDLE RIGS		
SIZE A4	DWG NO. BR-125024	REV
DATA SHEET		