

Cable Replacement Instructions for Series 2311 & 2315 Single Cable Lifts

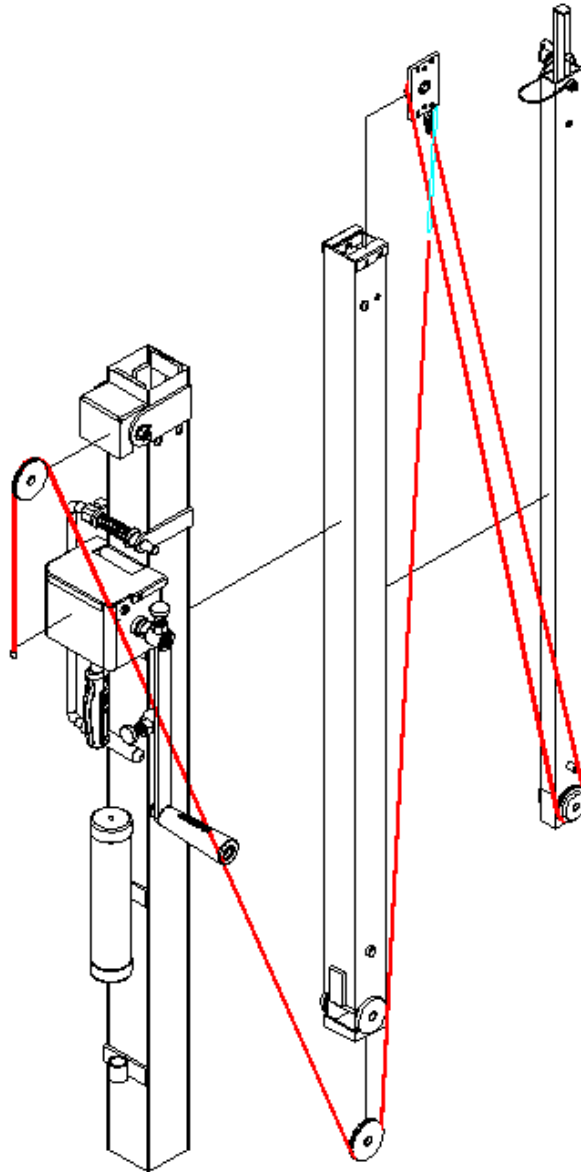

SUMNER

US
7514 Alabonson Road
Houston, TX 77088
phone: 281-999-6900
fax: 281-999-6966

Canada
75 Saltsman Drive, Unit 5
Cambridge, ON N3H 4R7
phone: 519-653-5300
fax: 519-653-5305

UK
Unit 16A
Blackpole Trading Estate East
Blackpole Road
Worcester WR3 8SG
phone: (44) 01905 458333
fax: (44) 01905 458222

Step 1



Remove cradle and base from mast assembly. Lay down mast assembly on a solid level work surface.

Step 2



Remove mast hold down assembly, (771055) screw and (772502) jam nut.

Step 3



Remove (776042) screws and (784408) pulley guard.

Step 4



Remove (776042) screws and (774428) winch cover.

Step 5



Remove (776042) screw from winch drum and remove cable as shown.

Step 6



Remove top outer mast components as shown.

Step 7

Remove (771044) screws and (784403) top cover from both sides of the center mast tube.

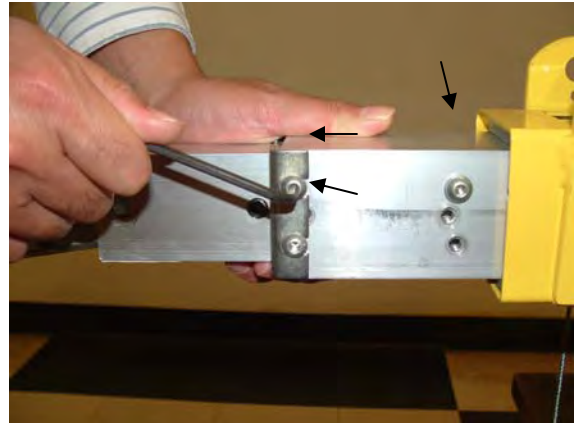

Step 8

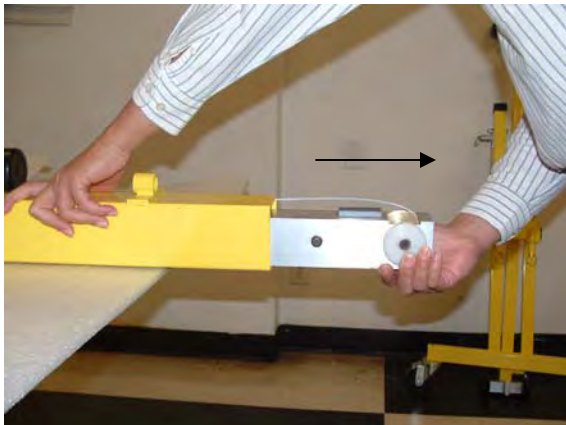

Remove center mast assembly from the bottom of the outer mast.

Step 9

Remove the pulley and wear pad from the bottom of the center mast.

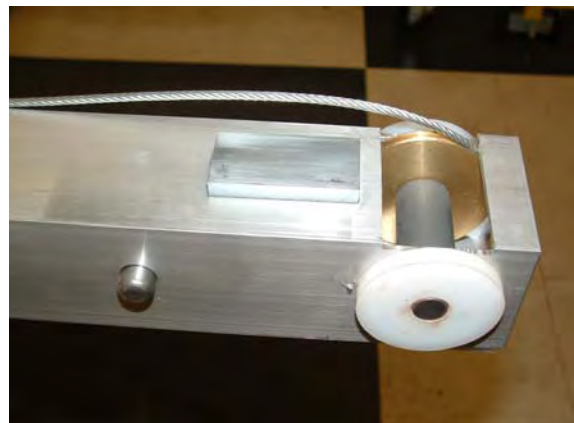

Step 10

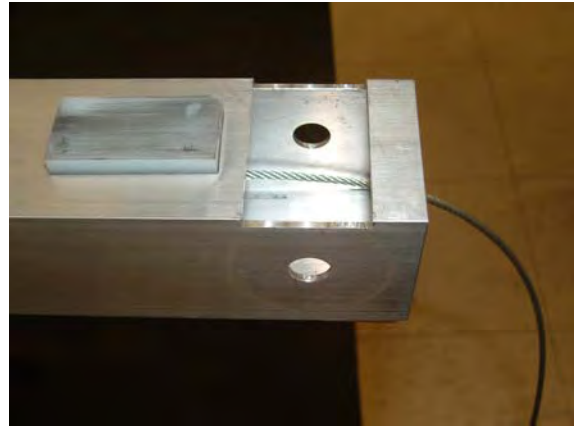
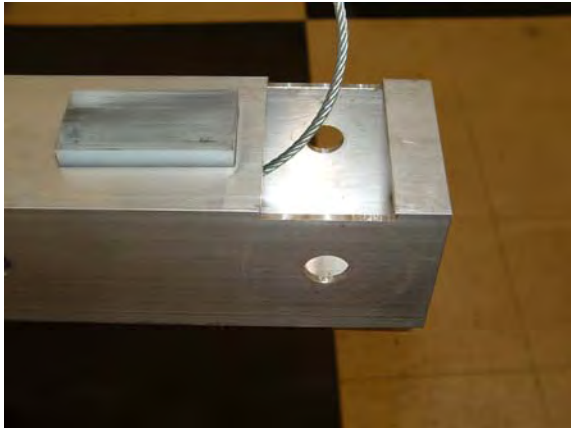

Pull cable from the loop position to a strait position through the bottom of the center mast for easy removal of top mast assembly.

Step 11

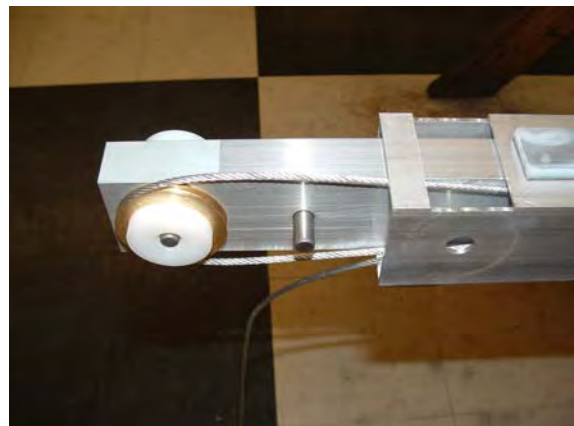

Pull top mast assembly slightly out the bottom of the center mast as shown and remove all hardware.

Step 12



Remove top mast tube from center mast.

Step 13

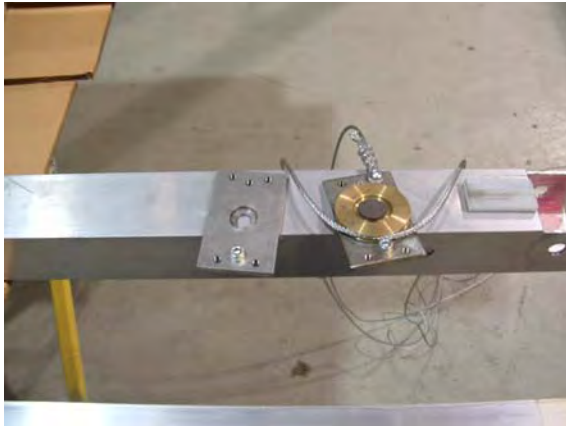

Remove (784399) center mast pulley weldment and (784398) pulley bracket from center mast.

Step 14



Lay down all mast sections on a solid level work surface. Make sure all components required to assemble the 2300 lift are at hand.

Step 15



Replace the damage load line as shown.

**Make sure cable is attached to the pulley weldment in the correct hole location and loop the cable in the right direction for proper installation of the cable. (Make note of this position upon removal)*

Step 16



Once cable is properly attach to the (784399) pulley weldment, give the cable the equal length of the center tube as shown.

Step 17

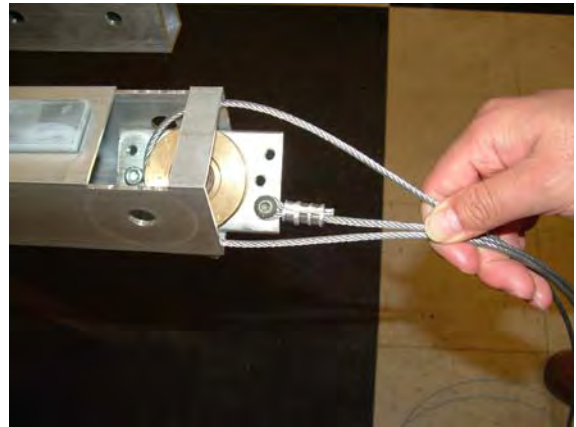
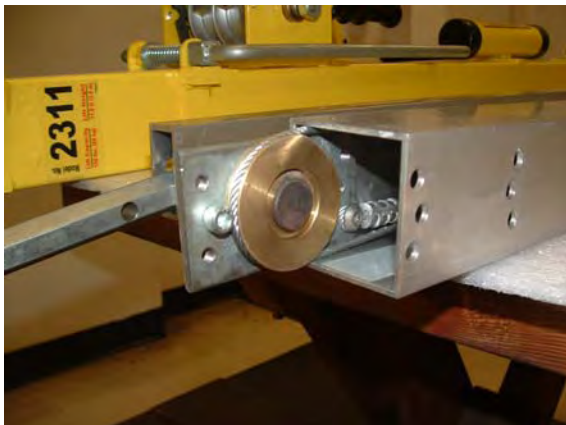

Insert (784398) center mast pulley weldment on right side (working from the bottom) and (784398) pulley bracket in left side into the center mast tube as shown.

Step 18

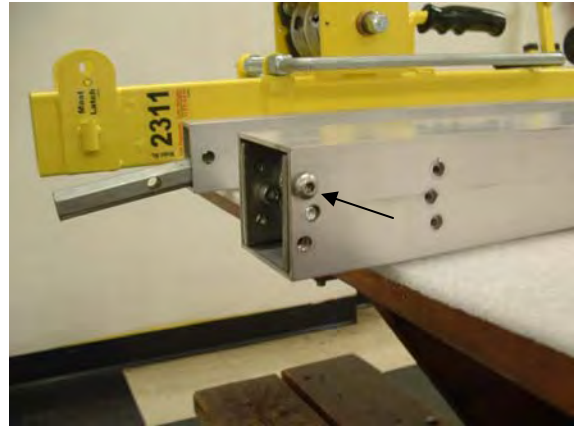

Locate (771044) screws and secure the (784399) center mast pulley weldment and (784398) pulley bracket as shown. Use only one screw at this time.

Step 19

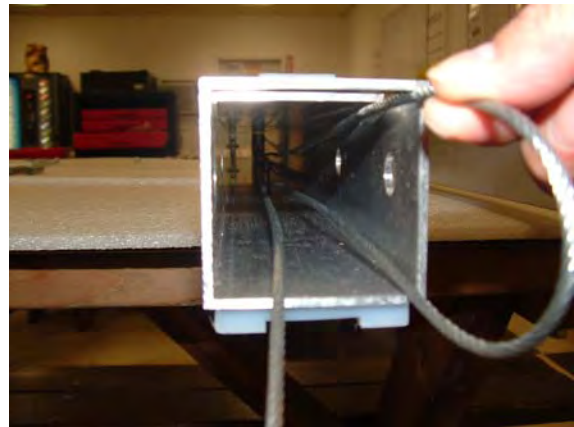

Straight cable as shown. Make sure cable is not tangle up inside the mast section.

Step 20

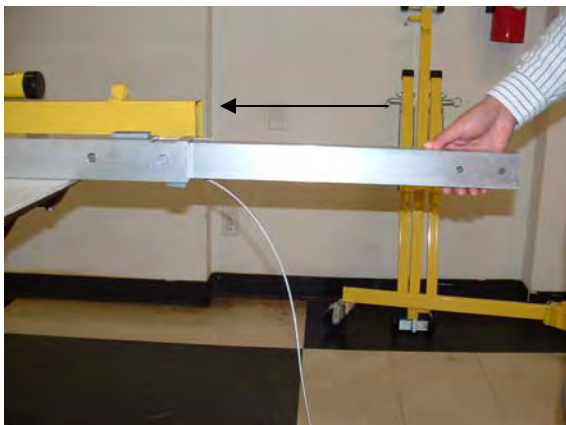

Insert top mast tube into center mast tube as shown.

Step 21

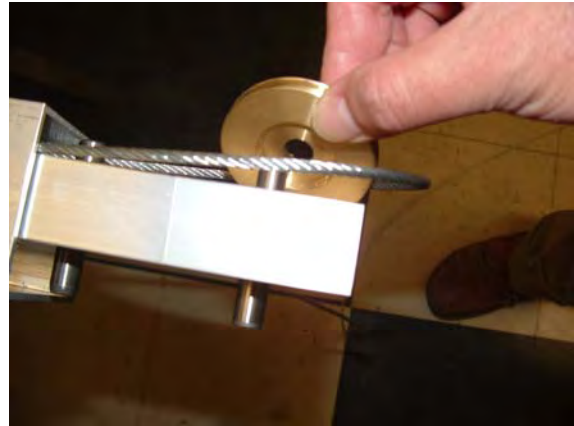

Locate (784412) top mast wear discs, (784391) 2 " pulley, (774041) dowel pin. Assemble components as shown.



Step 22

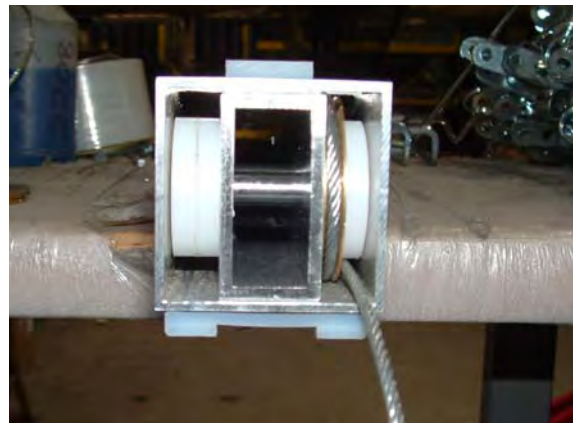
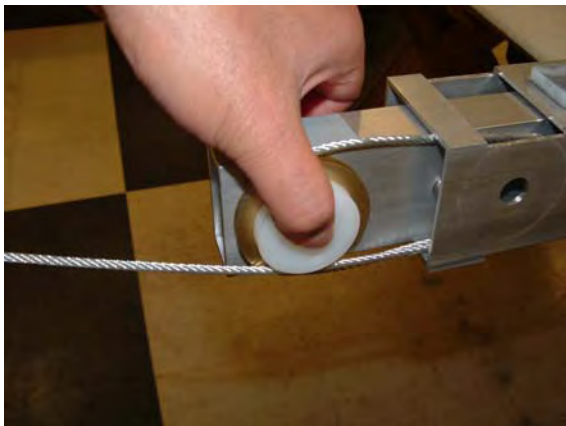

Insert top mast assembly into center mast tube by pulling the cable and stop when the end of the top mast passes the second hole of the center mast tube.

**Top mast should enter the center mast with ease, if there is stiffness check the cable and components for correct installation.*

Step 23

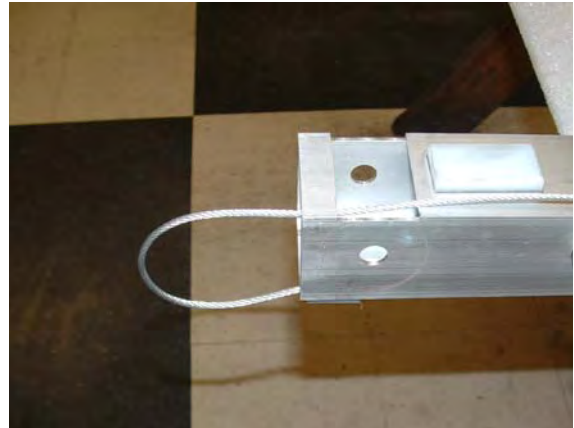
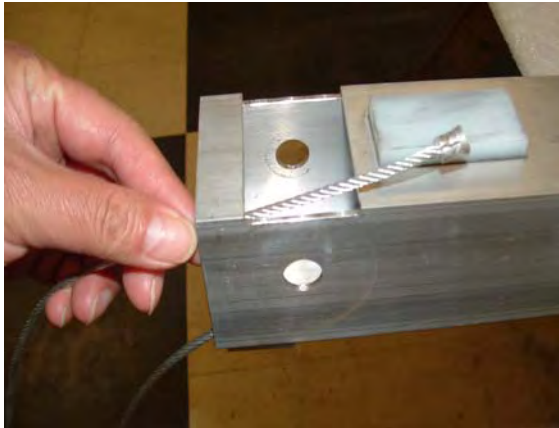

Insert and loop cable through the center mast slot as shown.

Step 24

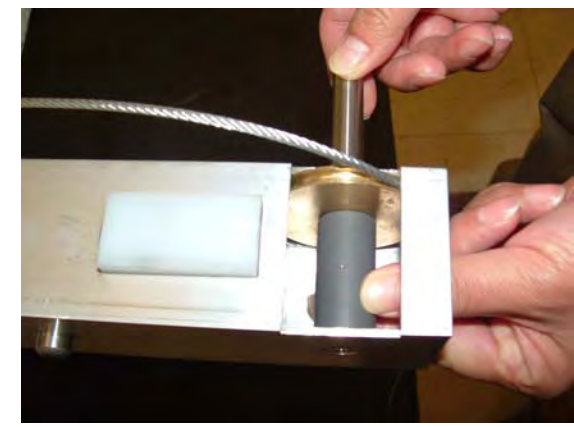

Locate (784404) center mast wear discs, (784390) 2-1/4" pulley, (774043) dowel pins and (784447) 1-5/8" pulley spacer. Assemble components as shown.

Step 25

Remove (771044) both screws on both sides from center mast tube.

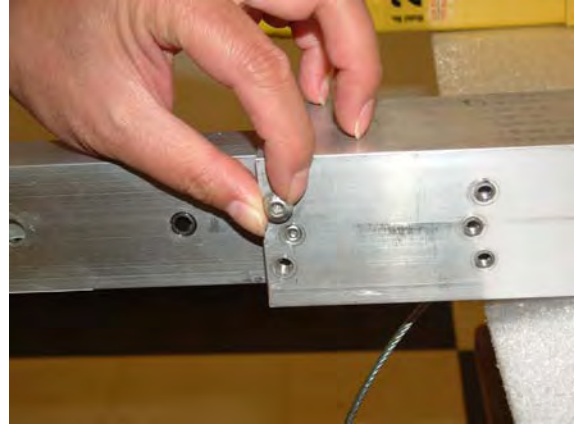

Step 26



Insert (774452) wear pads into slots on both sides as shown.

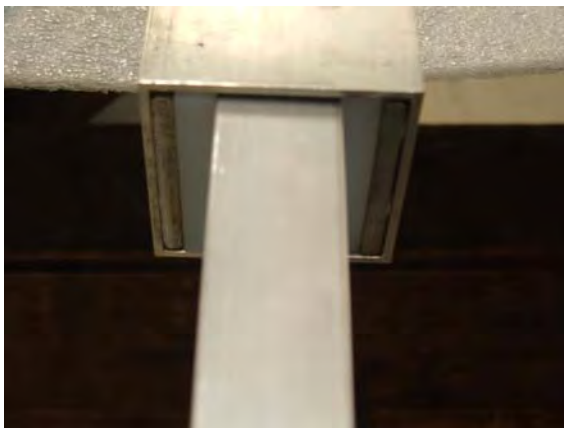

Step 27

Insert center mast assembly into the bottom of the outer mast weldment.



Step 28

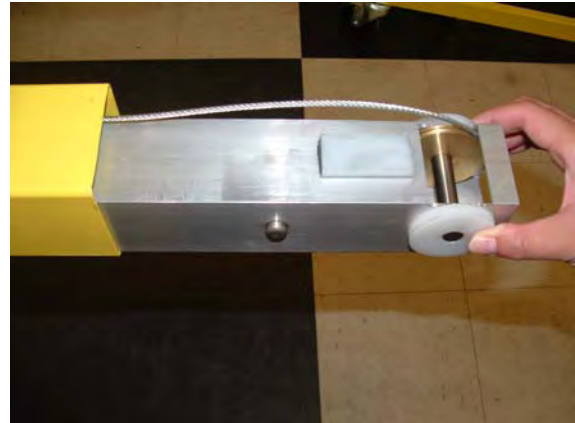
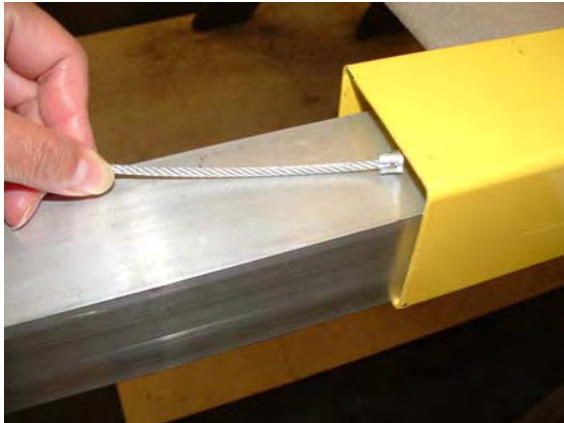

*Insert end of cable through the outer mast weldment as shown.
Feed the cable all the way to the top of the outer mast.

Step 29



*Locate (771044) screws, (773550) 1/4 lock washers, (784403) top covers and assemble them in both sides of center mast as shown.
The lock washer goes on the single screw circled. This screw must be in the correct position for proper operation.

Step 30



Locate (772355) 3/8 lock nut, (771137) screw, (784394) 1/2" pulley spacer, (784390) 2-1/4" pulley, (784446) 2" spacer and assemble has shown.

Step 31

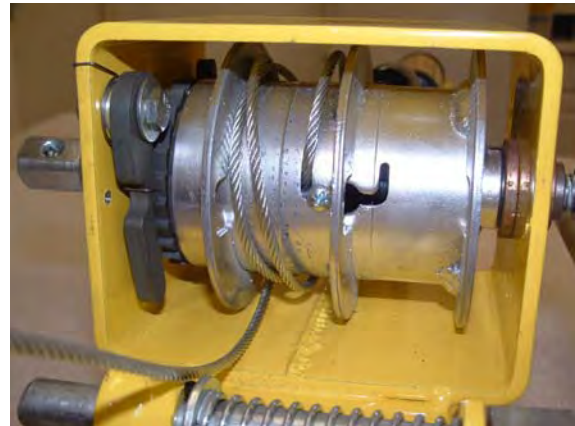

Insert cable in drum and secure with (776042) screw as shown.
*Once cable is secure wind the excess cable on the drum.

Step 32



Locate (784408) pulley guard, (776042) screws and assemble as shown.

Step 33



Assemble (784428) winch cover and secure with (776042) screws.

Step 34



Assemble mast hold down assembly into the top mast and secure with (771055) screw and (772502) jam nut.

** Inspect and test unit after completion.*