

1	2	3	4	5	6	7	
NO	P/N	Tooling	Working process	Description	REVISIONS		
1	SQZ-5090				SYM.	BY.	REVISIONS
					A.		DATE

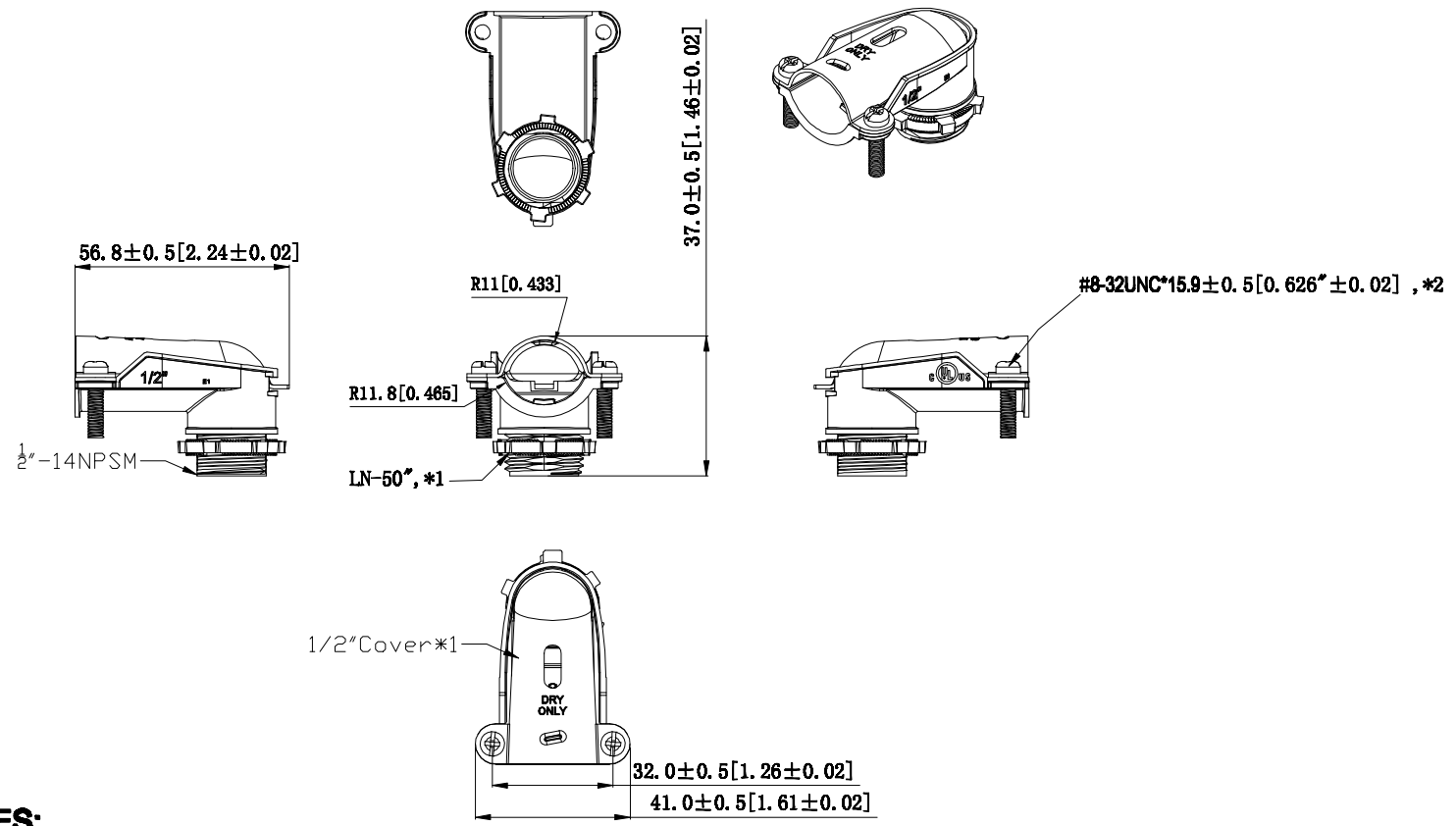

**NOTES:**  
 1. All dimensions in millimeters and [inches];  
 2. Free of sharp edge and burrs. max burr 0.5 [0.0196].  
 3. Material: #3 ZAMAK

THE QUALITY SYSTEM ISO 9001:2015 X.XC ±0.04[±0.01] X.XX ±0.07[±0.03] X.XXX ±0.08[±0.03] MATERIAL #3 ZAMAK FINISH DIMENSIONS SHOWN RESPECT PER ANSI Y14.5M-2018	NAME	DATE	<b>GARVIN INDUSTRIES</b> TITLE <b>ELECTRICAL TRADE WASHERS</b> SIZE A4 DWG NO. <b>SQZ-5090</b> REV SCALE: 1:1 PRINT DATE PART NUMBER SHEET 1 OF 1
	DRAWN	2014.01.09	
	CHECKED		
	APPROVED (A)		
	APPROVED (Customer)		